

# Part I - PHYSICS

02 / 06 / 2013

## SECTION – I (Only One option correct Type)

This section contains 8 **multiple choice questions**. Each question has 4 choices (A), (B), (C) and (D), out of which **ONE or MORE** are correct.

- Q.1** Two vehicles, each moving with speed  $u$  on the same horizontal straight road, are approaching each other. Wind blows along the road with velocity  $w$ . One of these vehicles blows a whistle of frequency  $f_1$ . An observer in the other vehicle hears the frequency of the whistle to be  $f_2$ . The speed of sound in still air is  $V$ . The correct statement(s) is (are)-
- (A) If the wind blows from the observer to the source,  $f_2 > f_1$   
 (B) If the wind blows from the source to the observer,  $f_2 > f_1$   
 (C) If the wind blows from the observer to the source,  $f_2 < f_1$   
 (D) If the wind blows from the source to the observer,  $f_2 < f_1$

**Ans.** [A,B]

**Sol.** When wind blows from observer to source

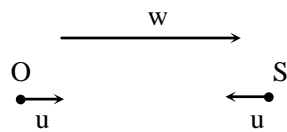

$$f_2 = f_1 \left[ \frac{v - w + u}{v - w - u} \right]$$

when wind flow from source to observer

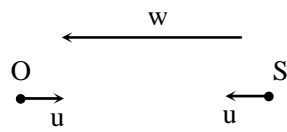

$$f_2 = f_1 \left[ \frac{v + w + u}{v + w - u} \right]$$

in both case

$$f_2 > f_1$$

- Q.2** A steady current  $I$  flows along an infinitely long hollow cylindrical conductor of radius  $R$ . This cylinder is placed coaxially inside an infinite solenoid of radius  $2R$ . The solenoid has  $n$  turns per unit length and carries a steady current  $I$ . Consider a point  $P$  at a distance  $r$  from the common axis. The correct statement(s) is (are)-
- (A) In the region  $0 < r < R$ , the magnetic field is non-zero  
 (B) In the region  $R < r < 2R$ , the magnetic field is along the common axis  
 (C) In the region  $R < r < 2R$ , the magnetic field is tangential to the circle of radius  $r$ , centered on the axis  
 (D) In the region  $r > 2R$ , the magnetic field is non-zero

Ans. [A,D]

Sol.

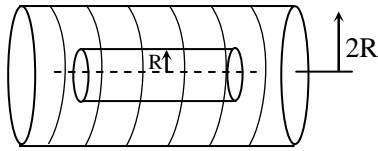

$0 < r < R$  is the point lying inside cylinder but lying inside solenoid.

$\therefore$  B due to cylinder = 0 but B due to solenoid  $\neq 0$ .  $\therefore$  as (A)

for  $r > 2R$  B is due to cylinder  $\neq 0$

However B due to solenoid = 0  $\therefore$  as (D)

**Q.3** A particle of mass  $m$  is attached to one end of a mass-less spring of force constant  $k$ , lying on a frictionless horizontal plane. The other end of the spring is fixed. The particle starts moving horizontally from its equilibrium position at time  $t = 0$  with an initial velocity  $u_0$ . When the speed of the particle is  $0.5 u_0$ , it collides elastically with a rigid wall.

(A) the speed of the particle when it returns to its equilibrium position is  $u_0$

(B) the time at which the particle passes through the equilibrium position for the first time is  $t = \pi \sqrt{\frac{m}{k}}$

(C) the time at which the maximum compression of the spring occurs is  $t = \frac{4\pi}{3} \sqrt{\frac{m}{k}}$

(D) the time at which the particle passes through the equilibrium position for the second time is  $t = \frac{5\pi}{3} \sqrt{\frac{m}{k}}$

Ans. [A,D]

Sol.

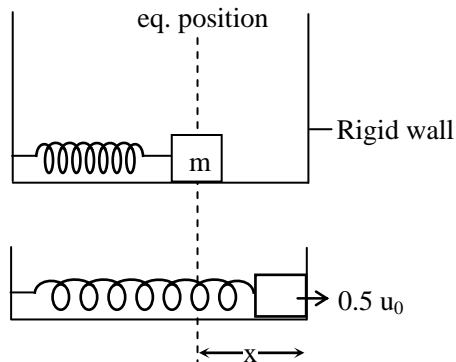

$$\frac{1}{2} m u_0^2 = \frac{1}{2} k x^2 + \frac{1}{2} m (0.5 u_0)^2 \quad \dots(i)$$

After elastic collision

block speed is  $0.5 u_0$

so when it will come back to equilibrium point

its speed will be  $u_0$  as (A)

$$\text{Amplitude } \frac{1}{2} m u_0^2 = \frac{1}{2} k A^2$$

$$A = \frac{u_0}{\sqrt{k}}$$

value of x from (i)

$$\frac{3}{4} \times \frac{1}{2} m u_0^2 = \frac{1}{2} k x^2$$

$$x = \frac{\sqrt{3} u_0}{2} \sqrt{\frac{m}{k}}$$

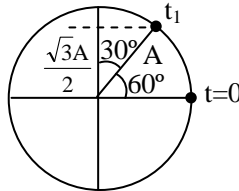

$$t_1 = \frac{\pi}{3\omega} = \frac{\pi\sqrt{m}}{3\sqrt{k}}$$

time to reach eq. position first time  $\Rightarrow \frac{2\pi}{3} \sqrt{\frac{m}{k}}$

second time it will reach at time  $\Rightarrow \frac{2\pi}{3} \sqrt{\frac{m}{k}} + \frac{T}{2} \Rightarrow \frac{2\pi}{3} \sqrt{\frac{m}{k}} + \frac{2\pi\sqrt{m}}{\sqrt{k} \times 2} \Rightarrow \frac{5\pi}{3} \sqrt{\frac{m}{k}}$  as (D)

for max. compression time is  $t_2$

$$\begin{aligned} t_2 &= \frac{2\pi}{3} \sqrt{\frac{m}{k}} + \frac{T}{4} \\ &= \frac{2\pi}{3} \sqrt{\frac{m}{k}} + \frac{2\pi}{\sqrt{k}} \frac{\sqrt{m}}{4} \\ &= \frac{7\pi}{6} \sqrt{\frac{m}{k}} \end{aligned}$$

**Q.4** Two bodies, each of mass  $M$ , are kept fixed with a separation  $2L$ . A particle of mass  $m$  is projected from the midpoint of the line joining their centres, perpendicular to the line. The gravitational constant is  $G$ . The correct statement(s) is (are)-

- (A) The minimum initial velocity of the mass  $m$  to escape the gravitational field of the two bodies is  $4\sqrt{\frac{GM}{L}}$
- (B) The minimum initial velocity of the mass  $m$  to escape the gravitational field of the two bodies is  $2\sqrt{\frac{GM}{L}}$
- (C) The minimum initial velocity of the mass  $m$  to escape the gravitational field of the two bodies is  $\sqrt{\frac{2GM}{L}}$
- (D) The energy of the mass  $m$  remains constant

**Ans.** [B,D]

Sol.

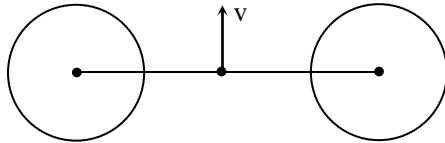

$$\frac{1}{2} m v_{\min}^2 + m \left[ -\frac{GM}{L} \times 2 \right] = 0 \quad \text{energy conservation}$$

$$\frac{v_{\min}^2}{2} = \frac{2GM}{L}$$

$$v_{\min} = 2\sqrt{\frac{GM}{L}} \quad \text{as (B)}$$

total energy of mass does not remain constant as net force on it is non-zero.

**Q.5** The radius of the orbit of an electron in a Hydrogen-like atom is  $4.5 a_0$ , where  $a_0$  is the Bohr radius. Its orbital angular momentum is  $\frac{3h}{2\pi}$ . It is given that  $h$  is Planck constant and  $R$  is Rydberg constant. The possible wavelength (s), when the atom de-excites, is(are)-

- (A)  $\frac{9}{32R}$                       (B)  $\frac{9}{16R}$                       (C)  $\frac{9}{5R}$                       (D)  $\frac{4}{3R}$

Ans. [A,C]

Sol.  $\frac{nh}{2\pi} = \frac{3h}{2\pi}$

$$n = 3$$

$$a_0 \times \frac{n^2}{Z} = 4.5 a_0$$

$$\frac{9}{Z} = 2$$

$$Z = 2$$

$$\frac{1}{\lambda_1} = R \times 2^2 \left[ \frac{1}{1} - \frac{1}{3^2} \right]$$

$$\frac{1}{\lambda_2} = 4R \left[ \frac{1}{2^2} - \frac{1}{3^2} \right]$$

$$\frac{1}{\lambda_3} = 4R \left[ \frac{1}{1} - \frac{1}{2^2} \right]$$

$$\lambda_1 = \frac{9}{32R}, \lambda_2 = \frac{9}{5R}, \lambda_3 = \frac{1}{3R}$$

- Q.6** The figure below shows the variation of specific heat capacity ( $C$ ) of a solid as a function of temperature ( $T$ ). The temperature is increased continuously from 0 to 500 K at a constant rate. Ignoring any volume change, the following statement(s) is (are) correct to a reasonable approximation.

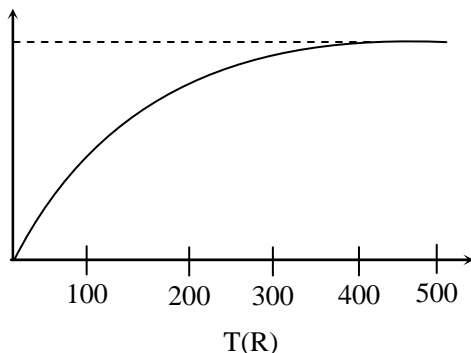

- (A) the rate at which heat is absorbed in the range 0-100 K varies linearly with temperature  $T$   
 (B) heat absorbed in increasing the temperature from 0-100 K is less than the heat required for increasing the temperature from 400-500 K.  
 (C) there is no change in the rate of heat absorption in the range 400-500 K  
 (D) the rate of heat absorption increases in the range 200-300 K

**Ans.** [B,C,D]

**Sol.**  $\frac{dT}{dt} = \text{constant}$

$$\frac{dH}{dt} = mC \frac{dT}{dt}$$

$C$  is constant 400 to 500 K  $\therefore \frac{dH}{dt} = \text{constant}$  as (C)

$C$  is increasing in range 200 to 300 K

$\therefore \frac{dH}{dt}$  increases as (D)

$$H_{0-100} = m \int_0^{100} C dT \Rightarrow \text{Area under the curve in } 0 - 100 = A_1$$

$$H_{400-500} = m \int_{400}^{500} C dT \Rightarrow \text{Area under the curve in } 400 - 500 = A_2$$

$$A_2 > A_1$$

$\therefore$  as (B)

- Q.7** Two non-conducting spheres of radii  $R_1$  and  $R$  and carrying uniform volume charge densities  $+\rho$  and  $-\rho$ , respectively, are placed such that they partially overlap, as shown in the figure. At all points in the overlapping region,

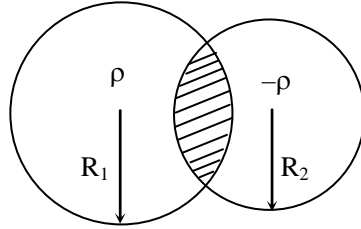

- (A) the electrostatic field is zero  
 (B) the electrostatic potential is constant  
 (C) the electrostatic field is constant in magnitude  
 (D) the electrostatic field has same direction

**Ans.** [C,D]

**Sol.**

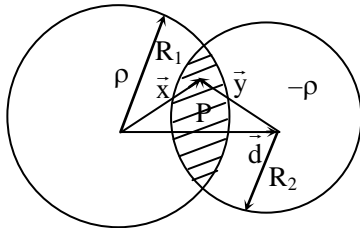

$$E \text{ at } P \Rightarrow \frac{\rho \vec{x}}{3\epsilon_0} + \frac{-\rho \vec{y}}{3\epsilon_0} \Rightarrow \frac{\rho \vec{d}}{3\epsilon_0}$$

so E is uniform  $\therefore$  as (C,D)

- Q.8** Using the expression  $2d \sin \theta = \lambda$ , one calculates the values of  $d$  by measuring the corresponding angles  $\theta$  in the range  $0$  to  $90^\circ$ . The wavelength  $\lambda$  is exactly known and the error in  $\theta$  is constant for all values of  $\theta$ . As  $\theta$  increases from  $0^\circ$ ,

- (A) the absolute error in  $d$  remains constant  
 (B) the absolute error in  $d$  increases  
 (C) the fractional error in  $d$  remains constant  
 (D) the fractional error in  $d$  decreases

**Ans.** [D]

**Sol.**  $2d \sin \theta = \lambda$

Let  $2d = y$

the  $y \sin \theta = \lambda$

$\log(y \sin \theta) = \log \lambda$

$\log y + \log \sin \theta = \log \lambda$

$$\frac{dy}{y} - \cot \theta = 0$$

$$\frac{dy}{y} = -\cot \theta$$

$$\left| \frac{dy}{y} \right| = \cot \theta$$

fractional error is decreases when  $\theta$  is increases

## SECTION – 2 (Paragraph Type)

This section contains 4 **paragraphs** each describing theory, experiment, data etc. **Eight questions** relate to four paragraphs with two questions on each paragraph. Each question of a paragraph has **only one correct answer** among the four choices (A), (B), (C) and (D).

**Paragraph for Questions 9 and 10**

A thermal power plant produces electric power of 600 kW at 4000 V, which is to be transported to a place 20 km away from the power plant for consumers usage. It can be transported either directly with a cable of large current carrying capacity or by using a combination of step-up and step-down transformers at the two ends. The drawback of the direct transmission is the large energy dissipation. In the method using transformers, the dissipation is much smaller. In this method, a step-up transformer is used at the plant side so that the current is reduced to a smaller value. At the consumers end, a step-down transformer is used to supply power to the consumers at the specified lower voltage. It is reasonable to assume that the power cable is purely resistive and the transformers are ideal with a power factor unity. All the currents and voltage mentioned are rms values.

- Q.9** In the method using the transformers, assume that the ratio of the number of turns in the primary to that in the secondary in the step-up transformer is 1 : 10. If the power to the consumers has to be supplied at 200 V, the ratio of the number of turns in the primary to that in the secondary in the step-down transformer is-
- (A) 200 : 1                      (B) 150 : 1                      (C) 100 : 1                      (D) 50 : 1

**Ans.** [A]

**Sol.** Using step up transformer

$$V_p = 4000 \text{ V}$$

$$\frac{N_p}{N_s} = \frac{1}{10}$$

$$\frac{4000}{V_s} = \frac{1}{10}$$

$$V_s = 40,000 \text{ volt}$$

40,000 volt is converted to 200 V using step down transformer

$$\frac{40000}{200} = \frac{N_p}{N_s}$$

$$\frac{N_p}{N_s} = \frac{200}{1}$$

- Q.10** If the direct transmission method with a cable of resistance  $0.4 \Omega \text{ km}^{-1}$  is used, the power dissipation (in %) during transmission is-
- (A) 20                      (B) 30                      (C) 40                      (D) 50

**Ans.** [B]

**Sol.** Direct transmission method

$$\text{Current} \Rightarrow \frac{600 \times 10^3}{4000} = 150 \text{ Amp.}$$

$$\begin{aligned} \text{Power loss} &= (150)^2 \times 0.4 \times 20 \\ &= 225 \times 100 \times 8 \\ &= 180 \text{ kW} \end{aligned}$$

$$\begin{aligned} \% \text{ loss} &= \frac{180}{600} \times 100 \\ &= 30 \% \end{aligned}$$

**Paragraph for Questions 11 and 12**

A small block of mass 1 kg is released from rest at the top of a rough track. The track is a circular arc of radius 40 m. The block slides along the track without toppling and a frictional force acts on it in the direction opposite to the instantaneous velocity. The work done in overcoming the friction up to the point Q, as shown in the figure below, is 150 J. (Take the acceleration due to gravity,  $g = 10 \text{ m/s}^2$ ).

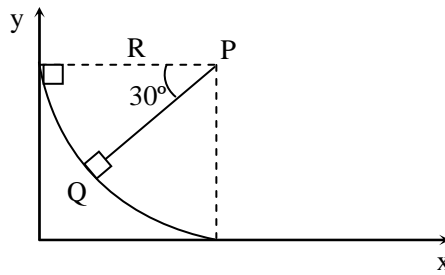

- Q.11** The magnitude of the normal reaction that acts on the block at the point Q is-
- (A) 7.5 N                      (B) 8.6 N                      (C) 11.5 N                      (D) 22.5 N

**Ans.** [A]

- Q.12** The speed of the block when it reaches the point Q is-
- (A) 5 m/s                      (B) 10 m/s                      (C)  $10\sqrt{3}$  m/s                      (D) 20 m/s

**Ans.** [B]

**Sol. Q.11 & Q.12**

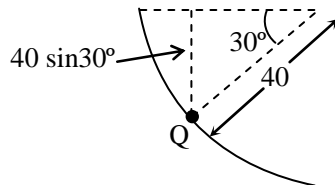

$$W \text{ by friction} + W \text{ by gravity} = \frac{1}{2} mv^2$$

$$-150 + mg \times 40 \sin 30^\circ = \frac{1}{2} \times 1 \times v^2$$



$$-150 + 1 \times 10 \times 20 = \frac{1}{2} v^2$$

$$100 = v^2$$

$$v = 10$$

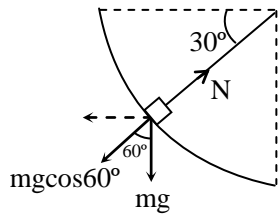

$$N - mg \cos 60^\circ = \frac{mv^2}{R}$$

$$N = mg \cos 60^\circ + \frac{mv^2}{R}$$

$$= 1 \times 10 \times \frac{1}{2} + \frac{1 \times 100}{40}$$

$$= 5 + 2.5$$

$$= 7.5 \text{ N}$$

#### Paragraph for Questions 13 and 14

The mass of a nucleus  ${}^A_Z X$  is less than the sum of the masses of  $(A-Z)$  number of neutrons and  $Z$  number of protons in the nucleus. The energy equivalent to the corresponding mass difference is known as the binding energy of the nucleus. A heavy nucleus of mass  $M$  can break into two light nuclei of masses  $m_1$  and  $m_2$  only if  $(m_1 + m_2) < M$ . Also two light nuclei of masses  $m_3$  and  $m_4$  can undergo complete fusion and form a heavy nucleus of mass  $M'$  only if  $(m_3 + m_4) > M'$ . The masses of some neutral atoms are given in the table below :

${}^1_1\text{H}$	1.007825 u	${}^2_1\text{H}$	2.014102 u	${}^3_1\text{H}$	3.016050 u	${}^4_2\text{He}$	4.002603 u
${}^6_3\text{Li}$	6.015123 u	${}^7_3\text{Li}$	7.016004 u	${}^{70}_{30}\text{Zn}$	69.925325 u	${}^{82}_{34}\text{Se}$	81.916709 u
${}^{152}_{64}\text{Gd}$	151.919803 u	${}^{206}_{82}\text{Pb}$	205.974455 u	${}^{209}_{83}\text{Bi}$	208.980388 u	${}^{210}_{84}\text{Po}$	209.982876 u

- Q.13** The kinetic energy (in keV) of the alpha particle, when the nucleus  ${}^{210}_{84}\text{Po}$  at rest undergoes alpha decay, is-
- (A) 5319                      (B) 5422                      (C) 5707                      (D) 5818

Ans. [A]

Sol.

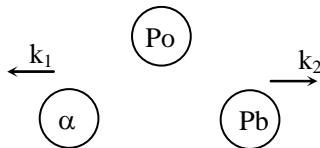

Momentum conservation

$$\sqrt{2m_{\alpha}k_1} = \sqrt{2m_{Pb}k_2}$$

$$\frac{k_1}{k_2} = \frac{m_{Pb}}{m_{\alpha}} = \frac{205}{4}$$

$k_1 + k_2 = Q$  value reaction

$$Q_{\text{value}} = 5.4 \text{ MeV}$$

$$k_1 = \frac{205}{209} \times 5.4 \text{ MeV}$$

$$= 5319 \text{ keV}$$

**Q.14** The correct statement is-

- (A) The nucleus  ${}^6_3\text{Li}$  can emit an alpha particle  
 (B) The nucleus  ${}^{210}_{84}\text{Po}$  can emit a proton  
 (C) Deuteron and alpha particle can undergo complete fusion  
 (D) The nuclei  ${}^{70}_{30}\text{Zn}$  and  ${}^{82}_{34}\text{Se}$  can undergo complete fusion

**Ans.** [C]

**Sol.**  $\text{Zn} + \text{Se} = \text{Gd}$

This is possible only when

$$m(\text{Zn}) + m(\text{Se}) > m(\text{Gd})$$

$$m(\text{Se}) + m(\text{Zn}) = 151.84$$

$$m(\text{Gd}) = 151.91803 \text{ u}$$

$\therefore$  option D is wrong

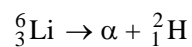

This is possible only  $m(\alpha) + m({}^2_1\text{H}) < m({}^6_3\text{Li})$

$$m(\alpha) + m({}^2_1\text{H}) = 6.016$$

$$m({}^6_3\text{Li}) = 6.015 \quad \therefore \text{option(A) is wrong}$$

option (C)



$m({}^2_1\text{H}) + m({}^4_2\text{He}) < m({}^6_3\text{Li})$  option is right so this is possible

## Paragraph for Questions 15 and 16

A point charge  $Q$  is moving in a circular orbit of radius  $R$  in the  $x$ - $y$  plane with an angular velocity  $\omega$ . This can be considered as equivalent to a loop carrying a steady current  $\frac{Q\omega}{2\pi}$ . A uniform magnetic field along the positive  $z$ -axis is now switched on, which increases at a constant rate from 0 to  $B$  in one second. Assume that the radius of the orbit remains constant. The application of the magnetic field induces an emf in the orbit. The induced emf is defined as the work done by induced electric field in moving a unit positive charge around a closed loop. It is known that, for an orbiting charge, the magnetic dipole moment is proportional to the angular momentum with a proportionally constant  $\gamma$ .

**Q.15** The change in the magnetic dipole moment associated with the orbit, at the end of the time interval of the magnetic field change, is

- (A)  $-\gamma BQR^2$       (B)  $-\gamma \frac{BQR^2}{2}$       (C)  $\gamma \frac{BQR^2}{2}$       (D)  $\gamma BQR^2$

**Ans.** [Either B or C]

**Sol.** Let  $M$  = magnetic moment;  $L$  = angular moment

given that  $M = \gamma L$

so  $\Delta M = \gamma \Delta L$

$$\therefore \Delta L = \int \tau dt \quad \dots(1)$$

for induced electric field

$$\int E \cdot dr = A \frac{dB}{dt}$$

$$E \int dr = A \cdot B \left( \because \frac{dB}{dt} = B \text{ given} \right)$$

$$E \times 2\pi R = \pi R^2 \cdot B$$

$$\boxed{E = \frac{RB}{2}} \quad \dots(2)$$

Now force on charge due to induced electric field

$$F = QE = \frac{QRB}{2}$$

$$\text{Torque } \tau = FR = \frac{QR^2B}{2}$$

by equation (1)

$$\therefore \Delta L = \int_0^1 \frac{QR^2B}{2} \cdot dt$$

$$\Delta L = \frac{QR^2B}{2} \cdot 1$$

$$\boxed{\Delta L = \frac{QR^2B}{2}} \quad \dots(3)$$

Since direction of motion of particle is not given that's why magnetic dipole moment may increase or decrease

**Q.16** The magnitude of the induced electric field in the orbit at any instant of time during the time interval of the magnetic field change is

- (A)  $\frac{BR}{4}$                       (B)  $\frac{BR}{2}$                       (C) BR                      (D) 2BR

**Ans.** [B]

**Sol.** for induced electric field

$$\int E \cdot dr = A \frac{dB}{dt}$$

$$E \int dr = A \cdot B \left( \because \frac{dB}{dt} = B \text{ given} \right)$$

$$E \times 2\pi R = \pi R^2 \cdot B$$

$$E = \frac{RB}{2}$$

### SECTION – 3 (Matching List Type)

This section contains **4 multiple choice questions**. Each question has matching lists. The codes for the lists have choices (A), (B), (C) and (D), out of which **ONLY ONE** is correct.

**Q.17** One mole of a monatomic ideal gas is taken along two cyclic processes  $E \rightarrow F \rightarrow G \rightarrow E$  and  $E \rightarrow F \rightarrow H \rightarrow E$  as shown in the PV diagram. The processes involved are purely isochoric, isobaric, isothermal or adiabatic.

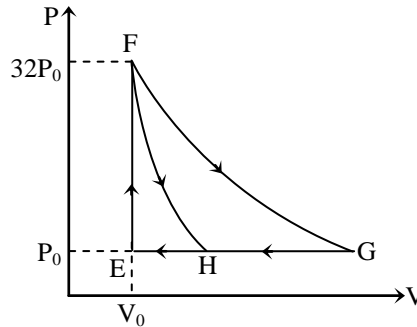

Match the paths in List-I with magnitude of the work done in List-II and select the correct answer using the codes given below the lists.

	List-I		List-II
P.	$G \rightarrow E$	1.	$160 P_0 V_0 \ln 2$
Q.	$G \rightarrow H$	2.	$36 P_0 V_0$
R.	$F \rightarrow H$	3.	$24 P_0 V_0$
S.	$F \rightarrow G$	4.	$31 P_0 V_0$

Codes :

	P	Q	R	S
(A)	4	3	2	1
(B)	4	3	1	2
(C)	3	1	2	4
(D)	1	3	2	4

Ans. [A]

Sol.

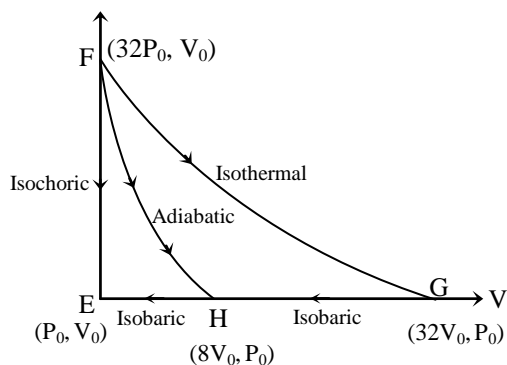

For process :

G - E Isobaric process

$$(W_{GE}) = P_0 \Delta V = P_0(32V_0 - V_0) = 31P_0V_0$$

G - H Isobaric process

$$(W_{GH}) = P_0 \Delta V = P_0(32V_0 - 8V_0) = 24 P_0V_0$$

F - H Adiabatic process

$$W = \frac{P_1 V_1 - P_2 V_2}{\gamma - 1} = \frac{32P_0 V_0 - 8P_0 V_0}{\frac{5}{3} - 1}$$

$$W = \frac{24P_0 V_0}{2/3} = 36 P_0V_0$$

F - G Isothermal process

$$W = nRT \ln \left[ \frac{V_2}{V_1} \right] = 1 \times R \times \frac{32P_0 V_0}{R} \ln [32] = 160 P_0V_0$$

**Q.18** Match List-I of the nuclear process with List-II containing parent nucleus and one of the end products of each process and then select the correct answer using the codes given below the lists :

**List-I**

P. Alpha decay

Q.  $\beta^+$  decay

R. Fission

S. Proton emission

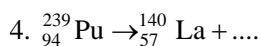
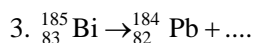
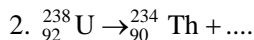
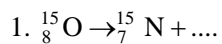
**List-II**

Codes :

	P	Q	R	S
(A)	4	2	1	3
(B)	1	3	2	4
(C)	2	1	4	3
(D)	4	3	2	1

Ans. [C]

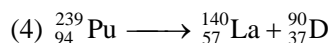
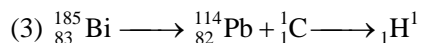
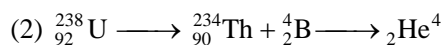
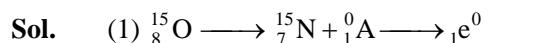

So,

1 is  $\longrightarrow \beta^+$  decay

2 is  $\longrightarrow \alpha$  - particle

3 is  $\longrightarrow$  Proton

4 is  $\longrightarrow$  fission

**Q.19** A right angled prism of refractive index  $\mu_1$  is placed in a rectangular block of refractive index  $\mu_2$ , which is surrounded by a medium of refractive index  $\mu_3$ , as shown in the figure. A ray of light 'e' enters the rectangular block at normal incidence. Depending upon the relationships between  $\mu_1$ ,  $\mu_2$  and  $\mu_3$ , it takes one of the four possible path 'ef', 'eg', 'eh' or 'ei'.

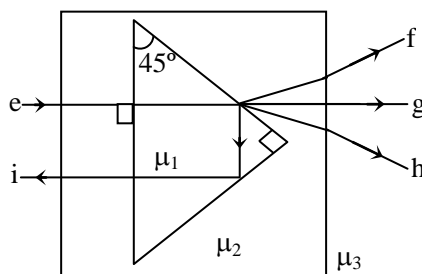

Match the paths in List –I with conditions of refractive indices in List-II and select the correct answer using the codes given below the lists:

	List-I		List-II
P.	$e \rightarrow f$	1.	$\mu_1 > \sqrt{2} \mu_2$
Q.	$e \rightarrow g$	2.	$\mu_2 > \mu_1$ and $\mu_2 > \mu_3$
R.	$e \rightarrow h$	3.	$\mu_1 = \mu_2$
S.	$e \rightarrow i$	4.	$\mu_2 < \mu_1 < \sqrt{2} \mu_2$ and $\mu_2 > \mu_3$

Codes :

	P	Q	R	S
(A)	2	3	1	4
(B)	1	2	4	3
(C)	4	1	2	3
(D)	2	3	4	1

Ans. [D]

Sol.

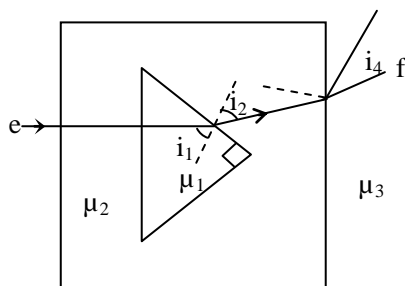

$$i_1 > i_2 \quad i_3 < i_4$$

$$\mu_2 > \mu_1 \quad \mu_3 > \mu_1$$

P → 2

For path

e → g

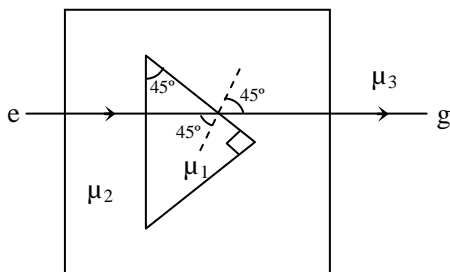

$$\therefore i_1 = i_2$$

$$\mu_1 = \mu_2$$

Q → 3

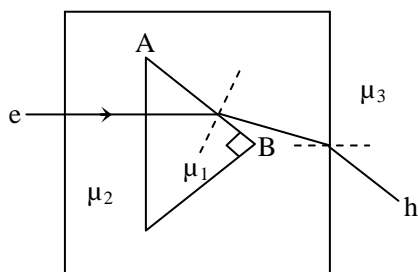

For path e → H

total internal reflection not take place at interface AB so

$$\theta_C > 45^\circ$$

$$\sin \theta_C > \sin 45^\circ$$

$$\frac{\mu_2}{\mu_1} > \frac{1}{\sqrt{2}}$$

$$\mu_1 < \sqrt{2} \mu_2$$

so,  $\mu_2 < \mu_1 < \sqrt{2} \mu_2$

For path e - i

$$\theta_C < 45^\circ$$

$$\text{so } \mu_1 > \sqrt{2} \mu_2$$

Q.20 Match List I with List II and select the correct answer using the codes given below the lists :

List I		List II	
P.	Boltzmann constant	1.	$[ML^2T^{-1}]$
Q.	Coefficient of viscosity	2.	$[ML^{-1}T^{-1}]$
R.	Planck constant	3.	$[MLT^{-3}K^{-1}]$
S.	Thermal conductivity	4.	$[ML^2T^{-2}K^{-1}]$

Codes :

	P	Q	R	S
(A)	3	1	2	4
(B)	3	2	1	4
(C)	4	2	1	3
(D)	4	1	2	3

Ans. [C]

Sol. **Boltzmann constant**

$$\therefore E = \frac{3}{2}KT$$

$$ML^2T^{-2} = k[K]$$

$$k = [ML^2T^{-2}K^{-1}]$$

**Coeff. of viscosity**

$$F = 6\pi\eta RV$$

$$\eta = \frac{MLT^{-2}}{L \times LT^{-1}}$$

$$\eta = [ML^{-1}T^{-1}]$$

**Planck constant**

$$E = hv$$

$$ML^2T^{-2} = h.T^{-1}$$

$$h = [ML^2T^{-1}]$$

**Thermal conductivity (K)**

$$K = [MLT^{-3}K^{-1}]$$



## Part II - CHEMISTRY

This section contains 8 **multiple choice questions**. Each question has 4 choices (A), (B), (C) and (D), out of which **ONE or MORE** are correct.

**Q.21** After completion of the reaction (I and II), the organic compound (s) in the reaction mixture is (are) -

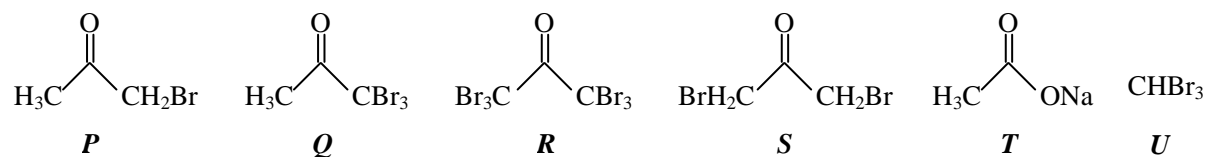
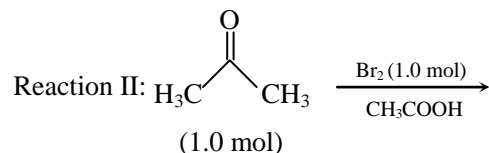
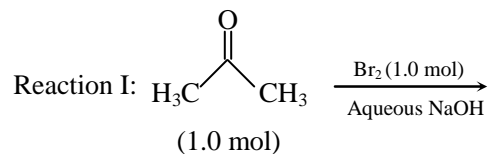

- (A) Reaction I : P and Reaction II : P  
 (B) Reaction I : U, acetone and Reaction II : Q, acetone  
 (C) Reaction I : T, U acetone and reaction II : P  
 (D) Reaction I : R, acetone and Reaction II : S, acetone

**Ans.** [C]  
**Sol.**

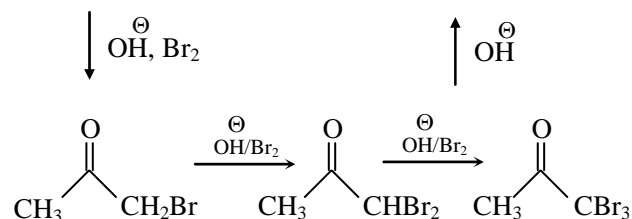
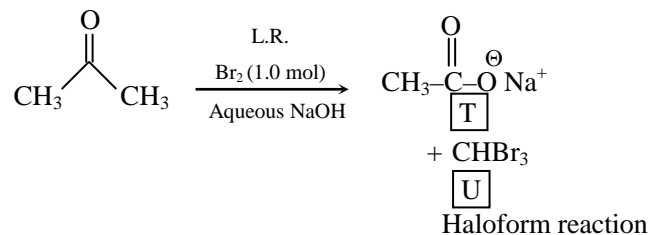

In Reaction (I)  
 In Reaction (II)

T, U are final product  
 Mono bromination occurs in acidic medium

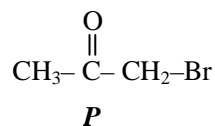

Q.22 The major products (s) of the following reaction is (are)

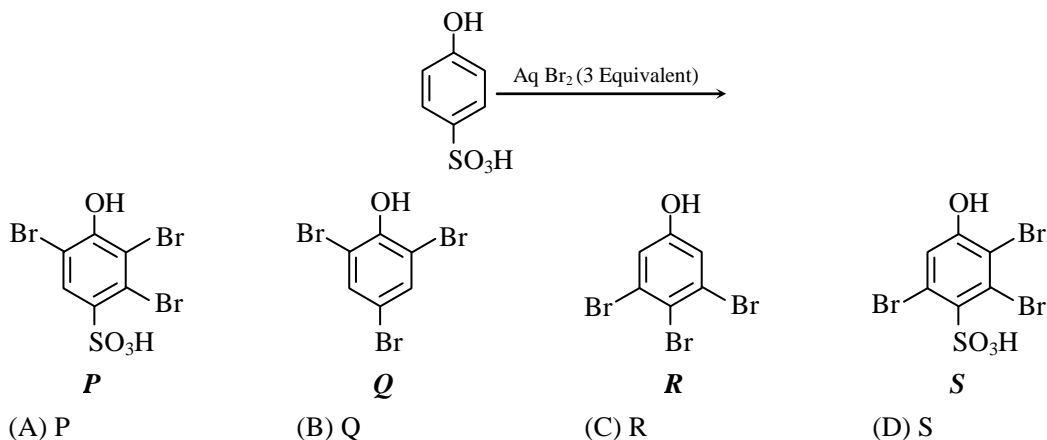

Ans. [B]

Sol.

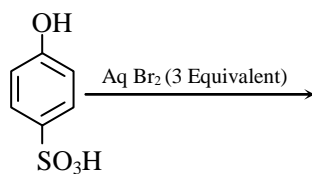

-OH is very activating & -SO<sub>3</sub>H very good leaving group so ans should be

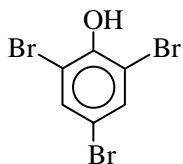

Q.23 In the following reaction, the product (s) formed is (are)-

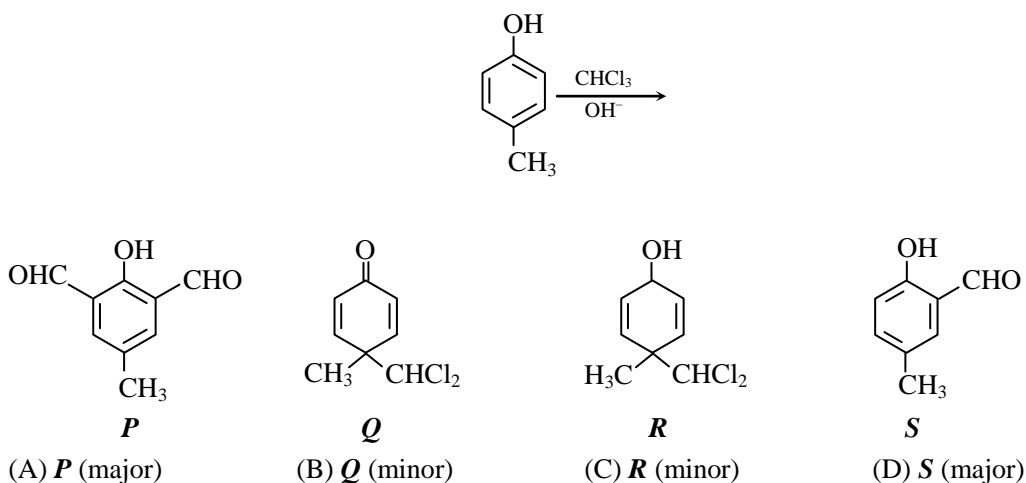

Ans. [B, D]

Sol.

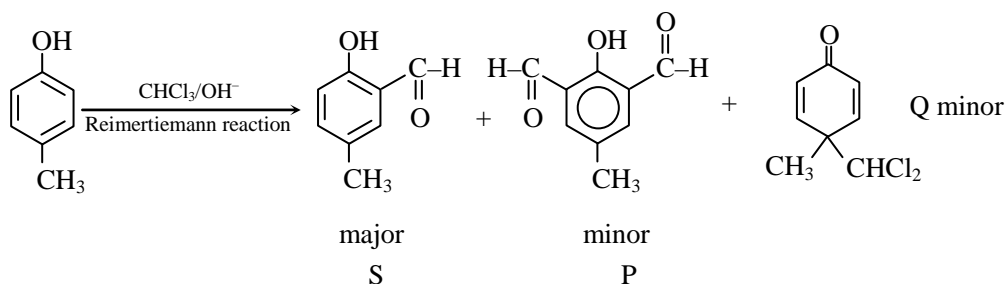

S     major  
Q     minor

- Q.24** The  $K_{sp}$  of  $Ag_2CrO_4$  is  $1.1 \times 10^{-12}$  at 298 K. at 298 K. The solubility (in mol/L) of  $Ag_2CrO_4$  in a 0.1 M  $AgNO_3$  solution is-  
 (A)  $1.1 \times 10^{-11}$                       (B)  $1.1 \times 10^{-10}$                       (C)  $1.1 \times 10^{-12}$                       (D)  $1.1 \times 10^{-9}$

Ans. [B]

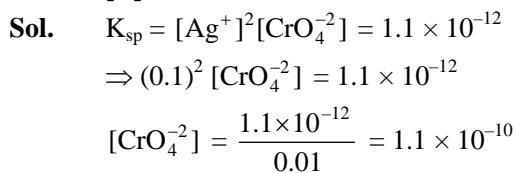

- Q.25** The thermal dissociation equilibrium of  $CaCO_3(s)$  is studied under different conditions .

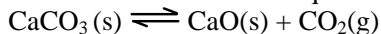

For this equilibrium, the correct statement (s) is (are)

- (A)  $\Delta H$  is dependent on T  
 (B) K is independent of the initial amount of  $CaCO_3$   
 (C) K is dependent on the pressure of  $CO_2$  at a given T  
 (D)  $\Delta H$  is independent of the catalyst, if any

Ans. [A,B,D]

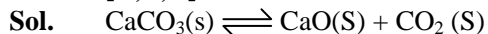

$$\ln k = \frac{\Delta H}{TR} + C$$

- \* K is independent of the initial amt. of  $CaCO_3$   
 \*  $\Delta H$  dependent on T  
 \*  $\Delta H$  is independent of catalyst

- Q.26** The carbon-based reduction is **NOT** used for the extraction of-  
 (A) tin from  $SnO_2$                       (B) iron from  $Fe_2O_3$   
 (C) aluminium from  $Al_2O_3$                       (D) magnesium from  $MgCO_3 \cdot CaCO_3$

Ans. [C,D]

**Sol.** Both Al and Mg are extracted by electrolytic reduction

- Q.27** In the nuclear transmutation

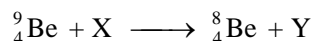

(X, Y) is(are) -

- (A) ( $\gamma$ , n)                      (B) (p, D)                      (C) (n, D)                      (D) ( $\gamma$ , p)

Ans. [A, B]

Sol.  ${}^9_4\text{Be} + \text{X} \rightarrow {}^8_4\text{Be} + \text{Y}$

(A)  ${}^9_4\text{Be} + \gamma \rightarrow {}^8_4\text{Be} + {}^1_0\text{n}$  (possible)

(C)  ${}^9_4\text{Be} + {}^1_0\text{n} \rightarrow {}^8_4\text{Be} + {}^2_1\text{H}$  (not possible)

(B)  ${}^9_4\text{Be} + {}^1_1\text{P} \rightarrow {}^8_4\text{Be} + {}^2_1\text{H}$  (possible)

(D)  ${}^9_4\text{Be} + \gamma \rightarrow {}^8_4\text{Be} + {}^1_1\text{P}$  (not possible)

Q.28 The correct statement(s) about  $\text{O}_3$  is(are) -

(A) O-O bond lengths are equal

(C)  $\text{O}_3$  is diamagnetic in nature

(B) Thermal decomposition of  $\text{O}_3$  is endothermic

(D)  $\text{O}_3$  has a bent structure

Ans. [A, C, D]

Sol.

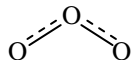

$\text{O}_3$  is diamagnetic and It has bent structure due to resonance both bonds have equal bond lengths

## SECTION - 2 (Paragraph Type)

This section contains 4 paragraphs each describing theory, experiment, data etc. **Eight questions** relate to four paragraphs with two questions on each paragraph. Each question of a paragraph has **only one correct answer** among the four choices (A), (B), (C) and (D).

### Paragraphs for Questions 29 and 30

P and Q are isomers of dicarboxylic acid  $\text{C}_4\text{H}_4\text{O}_4$ . Both decolorize  $\text{Br}_2/\text{H}_2\text{O}$ . On heating, P forms the cyclic anhydride. Upon treatment with dilute alkaline  $\text{KMnO}_4$ , P as well as Q could produce one or more than one from S, T and U

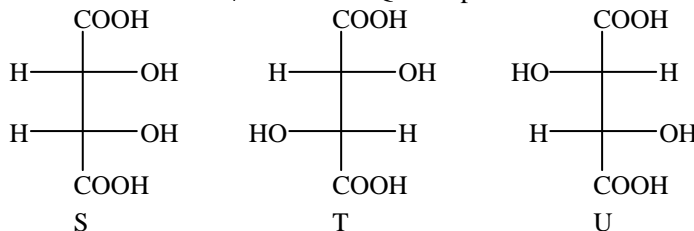

Q.29 In the following reaction sequences V and W are, respectively

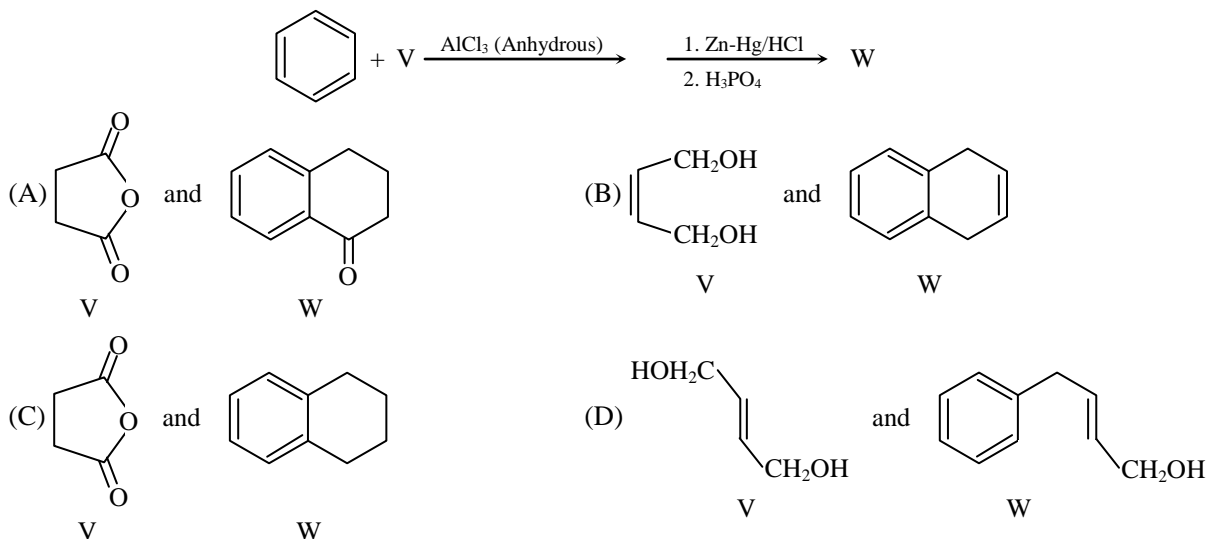
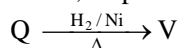

Ans. [A]

Sol.

P &amp; Q Dicarboxylic acid (unsaturated)

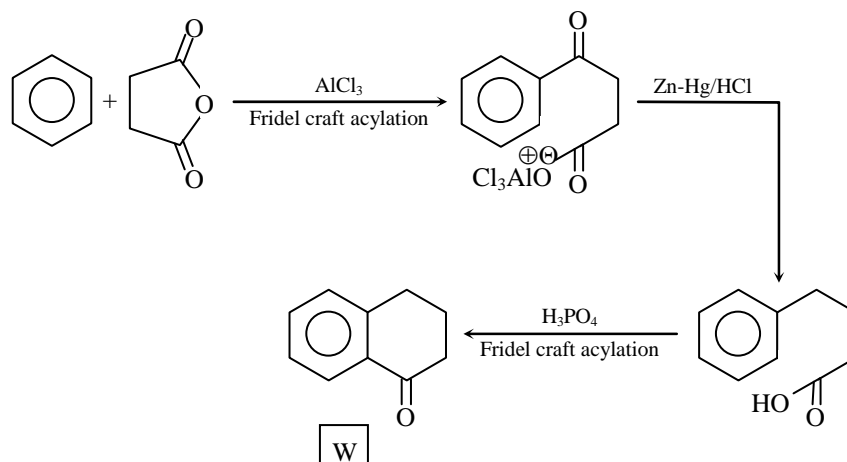
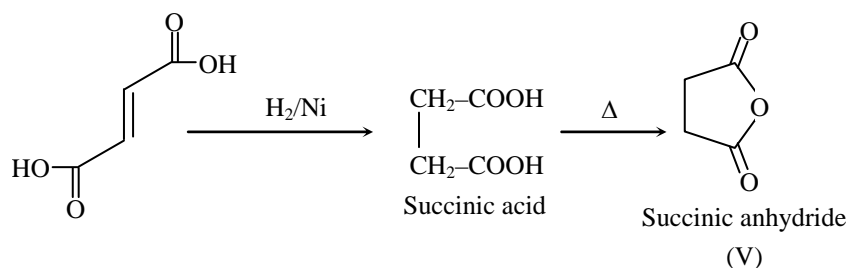
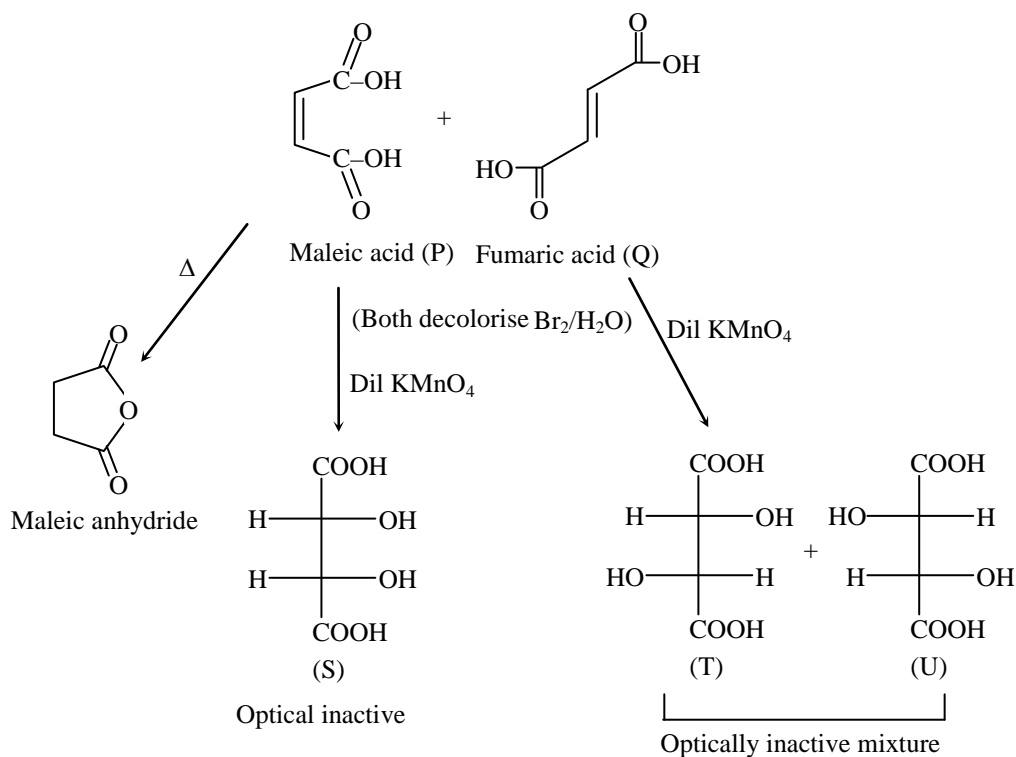

- Q.30** Compounds formed from P and Q are respectively  
 (A) Optically active S and optically active pair (T, U)  
 (B) Optically inactive S and optically inactive pair (T, U)  
 (C) Optically active pair (T, U) and optically active S  
 (D) Optically inactive pair (T, U) and optically inactive S

**Ans.** [B]

### Paragraphs for Questions 31 and 32

An aqueous solution of a mixture of two inorganic salts, when treated with dilute HCl, gave a precipitate (P) and a filtrate (Q). The precipitate P was found to dissolve in hot water. The filtrate (Q) remained unchanged, when treated with H<sub>2</sub>S in a dilute mineral acid medium. However, it gave a precipitate (R) with H<sub>2</sub>S in an ammoniacal medium.

The precipitate R gave a coloured solution (S), when treated with H<sub>2</sub>O<sub>2</sub> in an aqueous NaOH medium.

- Q.31** The coloured solution S contains  
 (A) Fe<sub>2</sub>(SO<sub>4</sub>)<sub>3</sub>                      (B) CuSO<sub>4</sub>                      (C) ZnSO<sub>4</sub>                      (D) Na<sub>2</sub>CrO<sub>4</sub>

**Ans.** [D]

**Sol.**

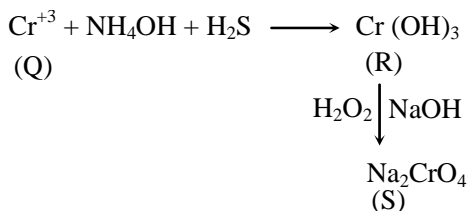

- Q.32** The precipitate P contains  
 (A) Pb<sup>2+</sup>                      (B) Hg<sub>2</sub><sup>2+</sup>                      (C) Ag<sup>+</sup>                      (D) Hg<sup>2+</sup>

**Ans.** [A]

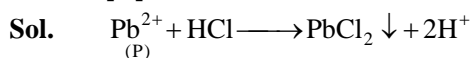

Soluble in hot water

### Paragraphs for Questions 33 and 34

The reactions of Cl<sub>2</sub> gas with cold-dilute and hot-concentrated NaOH in water give sodium salts of two (different) oxoacids of chlorine, P and Q, respectively. The Cl<sub>2</sub> gas reacts with SO<sub>2</sub> gas, in presence of charcoal, to give a product R. R reacts with white phosphorous to give a compound S. On hydrolysis, S gives an oxoacid of phosphorus, T.

- Q.33** R; S and T, respectively, are  
 (A) SO<sub>2</sub>Cl<sub>2</sub>, PCl<sub>5</sub> and H<sub>3</sub>PO<sub>4</sub>                      (B) SO<sub>2</sub>Cl<sub>2</sub>, PCl<sub>3</sub> and H<sub>3</sub>PO<sub>3</sub>  
 (C) SOCl<sub>2</sub>, PCl<sub>3</sub> and H<sub>3</sub>PO<sub>2</sub>                      (D) SOCl<sub>2</sub>, PCl<sub>5</sub> and H<sub>3</sub>PO<sub>4</sub>

**Ans.** [A]

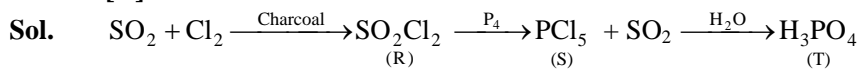

- Q.34** P and Q, respectively, are the sodium salts of  
 (A) Hypochlorous and chloric acids (B) Hypochlorous and chlorus acids  
 (C) Chloric and perchloric acids (D) Chloric and hypochlorous acids

**Ans.** [A]

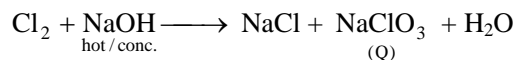
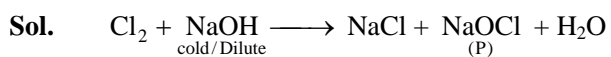

**Paragraph for Questions 35 and 36**

A fixed mass 'm' of a gas is subjected to transformation of states from K to L to M to N and back to K as shown in the figure.

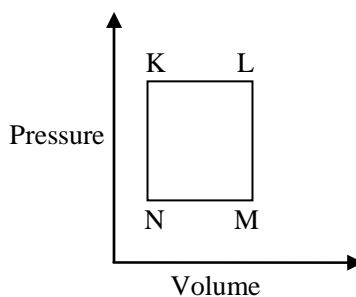

- Q.35** The pair of isochoric processes among the transformation of states is -  
 (A) K to L and L to M (B) L to M and N to K  
 (C) L to M and M to N (D) M to N and N to K

**Ans.** [B]

**Sol.** In process L to M & N to K  
 volume is constant so they are isochoric process

- Q.36** The succeeding operations that enable this transformation of states are -  
 (A) Heating, cooling, heating, cooling (B) Cooling, heating, cooling, heating  
 (C) Heating, cooling, cooling, heating (D) Cooling, heating, heating, cooling

**Ans.** [C]

**Sol.** In process K  $\longrightarrow$  L  $P \longrightarrow$  constant isobaric process,  $V \propto T \therefore V \uparrow T \uparrow$ ;  $\therefore$  heating  
 For L  $\longrightarrow$  M  $V \longrightarrow$  constant  $P \downarrow, P \propto T \therefore T \downarrow \therefore$  Cooling  
 For M  $\longrightarrow$  N  $P \longrightarrow$  constant  $V \downarrow, T \downarrow$ ;  $\therefore$  Cooling  
 For N  $\longrightarrow$  K  $P \uparrow, T \uparrow \therefore$  heating

## SECTION – 3 (Matching List Type)

This section contains **4 multiple choice questions**. Each question has **matching lists**. The codes for the lists have choices (A), (B), (C) and (D), out of which **ONLY ONE** is correct.

**Q.37** An aqueous solution of X is added slowly to an aqueous solution of Y as shown in List-I. The variation in conductivity of these reactions is given in List-II. Match List-I with List-II and select the correct answer using the code given below the lists -

	<b>List-I</b>		<b>List-II</b>
P.	$(C_2H_5)_3N + CH_3COOH$ X                      Y	1.	Conductivity decreases and then increases
Q.	$KI(0.1M) + AgNO_3(0.01M)$ X                      Y	2.	Conductivity decreases and then does not change much
R.	$CH_3COOH + KOH$ X                      Y	3.	Conductivity increases and then does not change much
S.	$NaOH + HI$ X                      Y	4.	Conductivity does not change much and then increases

**Codes :**

	P	Q	R	S
(A)	3	4	2	1
(B)	4	3	2	1
(C)	2	3	4	1
(D)	1	4	3	2

**Ans.** [A]

**Sol.** It is a question of conductometric titration

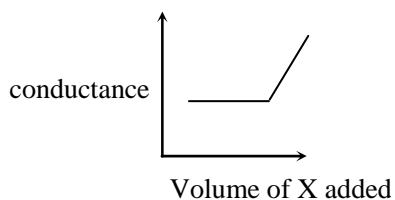
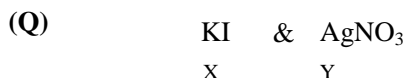
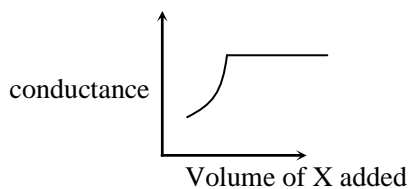
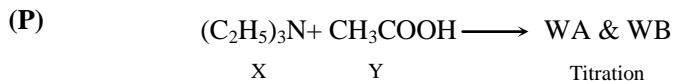



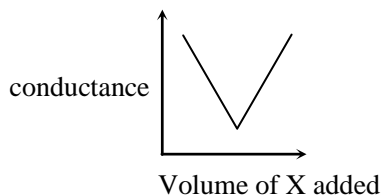
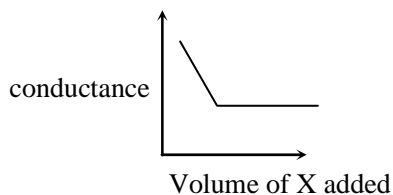
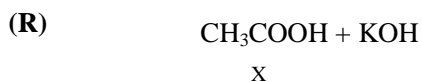

**Q.38** The standard reduction potential data at 25°C is given below.

$$E^\circ (\text{Fe}^{3+}, \text{Fe}^{2+}) = +0.77 \text{ V};$$

$$E^\circ (\text{Fe}^{2+}, \text{Fe}) = -0.44 \text{ V};$$

$$E^\circ (\text{Cu}^{2+}, \text{Cu}) = +0.34 \text{ V};$$

$$E^\circ (\text{Cu}^+, \text{Cu}) = +0.52 \text{ V};$$

$$E^\circ (\text{O}_2(\text{g}) + 4\text{H}^+ + 4\text{e}^- \rightarrow 2\text{H}_2\text{O}) = +1.23 \text{ V};$$

$$E^\circ (\text{O}_2(\text{g}) + 2\text{H}_2\text{O} + 4\text{e}^- \rightarrow 4\text{OH}^-) = +0.40 \text{ V};$$

$$E^\circ (\text{Cr}^{3+}, \text{Cr}) = -0.74 \text{ V};$$

$$E^\circ (\text{Cr}^{2+}, \text{Cr}) = -0.91 \text{ V}$$

Match  $E^\circ$  of the redox pair in List-I with the values given in List-II and select the correct answer using the code given below the lists –

	<b>List-I</b>		<b>List-II</b>
P.	$E^\circ(\text{Fe}^{3+}, \text{Fe})$	1.	-0.18 V
Q.	$E^\circ(4\text{H}_2\text{O} \rightleftharpoons 4\text{H}^+ + 4\text{OH}^-)$	2.	-0.4 V
R.	$E^\circ(\text{Cu}^{2+} + \text{Cu} \rightarrow 2\text{Cu}^+)$	3.	-0.04 V
S.	$E^\circ(\text{Cr}^{3+}, \text{Cr}^{2+})$	4.	-0.83 V

**Codes :**

	P	Q	R	S
(A)	4	1	2	3
(B)	2	3	4	1
(C)	1	2	3	4
(D)	3	4	1	2

**Ans.** [D]



Sol. (P)

$$\begin{aligned}
 & \text{Fe}^{+3} + e^{-} \rightarrow \text{Fe}^{+2} \quad \Delta G_1^{\circ} \\
 & \text{Fe}^{+2} + 2e^{-} \rightarrow \text{Fe} \quad \Delta G_2^{\circ} \\
 \hline
 & \text{Fe}^{+3} + 3e^{-} \rightarrow \text{Fe} \quad \Delta G_3^{\circ} \\
 & \Delta G_3^{\circ} = \Delta G_1^{\circ} + \Delta G_2^{\circ} \\
 = & \frac{n_1 E_1^{\circ} + n_2 E_2^{\circ}}{n_3} \\
 = & \frac{1 \times .77 + 2 \times (-.44)}{3} \\
 & -0.04
 \end{aligned}$$

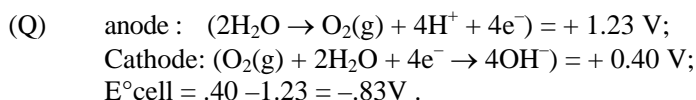

(R)  $E^{\circ}\text{cell} = \text{SRP} - \text{SRP}$   
 (c) (a)  
 $= .34 - .52$   
 $= -.18\text{V}$

(S)  $\text{Cr}^{+3} + 3e^{-} \rightarrow \text{Cr} \quad \Delta G_1^{\circ}$   
 $\text{Cr}^{+2} + 2e^{-} \rightarrow \text{Cr} \quad \Delta G_2^{\circ}$   
 $\hline$   
 $\text{Cr}^{+3} + e^{-} \rightarrow \text{Cr}^{+2} \quad \Delta G_3^{\circ}$   
 $\hline$   
 $\Delta G_3^{\circ} = \Delta G_1^{\circ} - \Delta G_2^{\circ}$   
 $-n_3 E_3^{\circ} = -n_3 E_1^{\circ} + n_2 E_2^{\circ}$   
 $E_3^{\circ} = \frac{n_1 E_1^{\circ} - n_2 E_2^{\circ}}{n_3}$   
 $= \frac{3(-.74) - (2 \times -.91)}{1}$   
 $= -.4\text{V}$

**Q.39** The unbalanced chemical reactions given in List I show missing reagent or condition (?) which are provided in List II. Match List I with List II and select the correct answer using the code given below lists :

	<b>List-I</b>		<b>List-II</b>
P.	$\text{PbO}_2 + \text{H}_2\text{SO}_4 \xrightarrow{?} \text{PbSO}_4 + \text{O}_2 + \text{other product}$	1.	NO
Q.	$\text{Na}_2\text{S}_2\text{O}_3 + \text{H}_2\text{O} \xrightarrow{?} \text{NaHSO}_4 + \text{other product}$	2.	$\text{I}_2$
R.	$\text{N}_2\text{H}_4 \xrightarrow{?} \text{N}_2 + \text{other product}$	3.	Warm
S.	$\text{XeF}_2 \xrightarrow{?} \text{Xe} + \text{other product}$	4.	$\text{Cl}_2$

Codes :

	P	Q	R	S
(A)	4	2	3	1
(B)	3	2	1	4
(C)	1	4	2	3
(D)	3	4	2	1

Ans. [D]

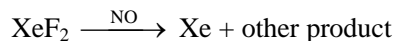
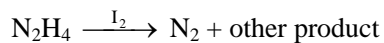
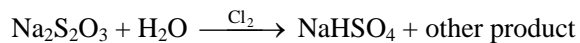
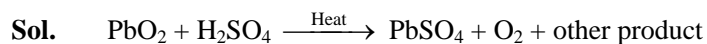

**Q.40** Match the chemical conversions in List-I with the appropriate reagents in List-II and select the correct answer using the code given below the lists -

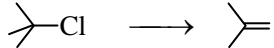
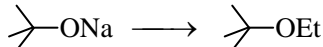
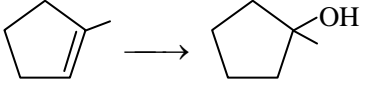
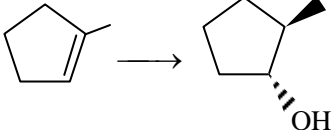
	List-I		List-II
P.		→	1. (i) $\text{Hg}(\text{OAc})_2$ ; (ii) $\text{NaBH}_4$
Q.		→	2. $\text{NaOEt}$
R.		→	3. $\text{Et-Br}$
S.		→	4. (i) $\text{BH}_3$ ; (ii) $\text{H}_2\text{O}_2/\text{NaOH}$

**Codes :**

	P	Q	R	S
(A)	2	3	1	4
(B)	3	2	1	4
(C)	2	3	4	1
(D)	3	2	4	1

**Ans.** [A]

**Sol.** P – 2 [Elimination  $-\text{E}^2$ ]

Q – 3 [Williamson etherification]

R – 1 [OMDM]

S – 4 [HBO]

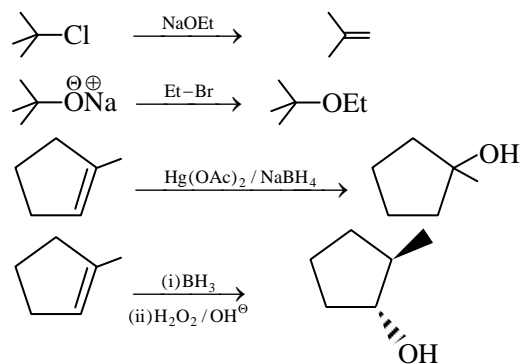

## Part III - Mathematics

### SECTION – 1 (Only or More option correct Type)

This section contains 8 **multiple choice questions**. Each question has four choices (A), (B), (C) and (D), out of which **ONE or MORE** are correct.

- Q.41** In a triangle PQR, P is the largest angle and  $\cos P = \frac{1}{3}$ . Further the incircle of the triangle touches the sides PQ, QR and RP at N, L and M respectively, such that the lengths of PN, QL and RM are consecutive even integers. Then possible length(s) of the side(s) of the triangle is (are) -
- (A) 16                      (B) 18                      (C) 24                      (D) 22

**Ans.** [B,D]

**Sol.**

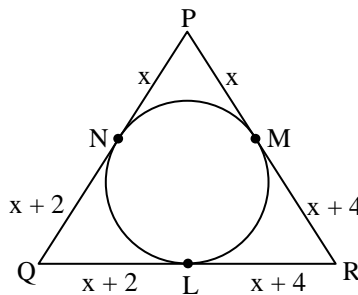

$$\cos P = \frac{(2x+2)^2 + (2x+4)^2 - (2x+6)^2}{2(2x+2)(2x+4)}$$

$$\Rightarrow \frac{1}{3} = \frac{4x^2 - 16}{2(4x^2 + 12x + 8)}$$

$$\Rightarrow 8x^2 + 24x + 16 = 12x^2 - 48$$

$$\Rightarrow 4x^2 - 24x - 64 = 0$$

$$\Rightarrow x^2 - 6x - 16 = 0$$

$$\Rightarrow (x-8)(x+2) = 0$$

$$\Rightarrow x = 8$$

So the sides of triangles are, 18, 20, 22.

- Q.42** Two lines  $L_1 : x = 5, \frac{y}{3-\alpha} = \frac{z}{-2}$  and  $L_2 : x = \alpha, \frac{y}{-1} = \frac{z}{2-\alpha}$  are coplanar, Then  $\alpha$  can take value(s) -
- (A) 1                      (B) 2                      (C) 3                      (D) 4

**Ans.** [A,D]

**Sol.** Direction ratios of  $L_1$  are  $(0, \alpha - 3, 2)$  and it passes through the point  $(5, 0, 0)$  and direction ratios of  $L_2$  are  $(0, 1, \alpha - 2)$  and it passes through the point  $(\alpha, 0, 0)$   
If  $L_1$  &  $L_2$  are coplanar then

$$\begin{vmatrix} 5-\alpha & 0 & 0 \\ 0 & \alpha-3 & 2 \\ 0 & 1 & \alpha-2 \end{vmatrix} = 0$$

$$(5-\alpha)[(\alpha-3)(\alpha-2)-2] = 0$$

$$(5-\alpha)(\alpha^2-5\alpha+4) = 0$$

$$(5-\alpha)(\alpha-1)(\alpha-4) = 0$$

So  $\alpha = 1, 4, 5$

**Q.43** Circle(s) touching x-axis at a distance 3 from the origin and having an intercept of length  $2\sqrt{7}$  on y-axis is (are) -

(A)  $x^2 + y^2 - 6x + 8y + 9 = 0$

(B)  $x^2 + y^2 - 6x + 7y + 9 = 0$

(C)  $x^2 + y^2 - 6x - 8y + 9 = 0$

(D)  $x^2 + y^2 - 6x - 7y + 9 = 0$

**Ans.** [A,C]

**Sol.**

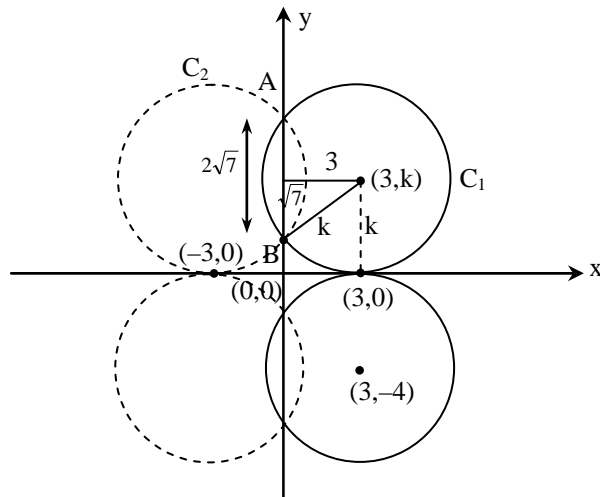

$$k = \sqrt{9+7} = 4$$

Circle is

$$(x-3)^2 + (y-4)^2 = 16$$

$$x^2 + y^2 - 6x - 8y + 9 = 0$$

or

$$(x+3)^2 + (y-4)^2 = 16$$

$$x^2 + y^2 + 6x - 8y + 9 = 0$$

or

$$(x-3)^2 + (y+4)^2 = 16 \text{ which is option (A).}$$



**Q.44** For  $a \in \mathbb{R}$  (the set of all real numbers),  $a \neq -1$ ,

$$\lim_{n \rightarrow \infty} \frac{(1^a + 2^a + \dots + n^a)}{(n+1)^{a-1}[(na+1) + (na+2) + \dots + (na+n)]} = \frac{1}{60}. \text{ Then } a =$$

- (A) 5                                      (B) 7                                      (C)  $\frac{-15}{2}$                                       (D)  $\frac{-17}{2}$

**Ans.** [B,D]

**Sol.**

$$\begin{aligned} \lim_{n \rightarrow \infty} \frac{1^a + 2^a + \dots + n^a}{(n+1)^{a-1} \left[ n^2 a + \frac{n(n+1)}{2} \right]} \\ &= \lim_{n \rightarrow \infty} \frac{n^a \left[ \left( \frac{1}{n} \right)^a + \left( \frac{2}{n} \right)^a + \dots + 1 \right]}{n^{a-1} \left( 1 + \frac{1}{n} \right)^{a-1} n^2 \left[ a + \frac{(1+1/n)}{2} \right]} \\ &= \lim_{n \rightarrow \infty} \frac{1}{\left( 1 + \frac{1}{n} \right)^{a-1} \left[ a + \frac{1+1/n}{2} \right]} \cdot \int_0^1 x^a dx \\ &= \frac{1}{a + \frac{1}{2}} \left( \frac{x^{a+1}}{a+1} \right)_0^1 \\ &= \frac{2}{(2a+1)} \times \frac{1}{a+1} = \frac{1}{60} \\ \Rightarrow (2a+1)(a+1) &= 12a \\ \Rightarrow 2a^2 + 3a + 1 &= 12a \\ \Rightarrow 2a^2 + 3a - 119 &= 0 \\ \Rightarrow (a-7)(2a+17) &= 0 \\ a = 7, \frac{-17}{2} \end{aligned}$$

**Q.45** The function  $f(x) = 2|x| + |x+2| - ||x+2| - 2|x||$  has a local minimum or a local maximum at  $x =$

- (A) -2                                      (B)  $\frac{-2}{3}$                                       (C) 2                                      (D)  $\frac{2}{3}$

**Ans.** [A,B]

**Sol.**

$$\begin{aligned} f(x) &= 2|x| + |x+2| - ||x+2| - 2|x|| \\ &= \begin{cases} -2x-4, & x < -2 \\ 2x+4, & -2 \leq x < -\frac{2}{3} \\ -4x, & -\frac{2}{3} \leq x < 0 \\ 4x, & 0 \leq x < 2 \\ 2x+4, & x \geq 2 \end{cases} \end{aligned}$$

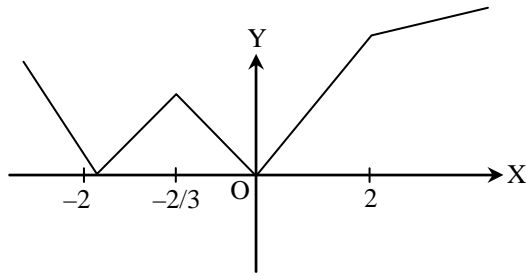

Clearly point of minima  $x = -2, 0$

$$\text{Point of maxima } x = \frac{-2}{3}$$

**Q.46** Let  $\omega$  be a complex cube root of unity with  $\omega \neq 1$  and  $P = [p_{ij}]$  be a  $n \times n$  matrix with  $p_{ij} = \omega^{i+j}$ . Then  $P^2 \neq 0$ , when  $n =$

- (A) 57                                      (B) 55                                      (C) 58                                      (D) 56

**Ans.** [B,C,D]

**Sol.** 
$$P = \begin{bmatrix} \omega^2 & \omega^3 & \dots & \omega^{n+1} \\ \omega^3 & \omega^4 & \dots & \omega^{n+2} \\ \vdots & \vdots & \dots & \vdots \\ \omega^{n+1} & \omega^{n+2} & \dots & \omega^{2n} \end{bmatrix}$$

$$P = \omega^2 \omega^3 \dots \omega^{n+1} \begin{bmatrix} 1 & \omega & \dots & \omega^{n-1} \\ 1 & \omega & \dots & \omega^{n-1} \\ \vdots & \vdots & \dots & \vdots \\ 1 & \omega & \dots & \omega^{n-1} \end{bmatrix}$$

Now

$$P^2 = \omega^{n^2+3n} \begin{bmatrix} 1 & \omega & \dots & \omega^{n-1} \\ 1 & \omega & \dots & \omega^{n-1} \\ \vdots & \vdots & \dots & \vdots \\ 1 & \omega & \dots & \omega^{n-1} \end{bmatrix} \begin{bmatrix} 1 & \omega & \dots & \omega^{n-1} \\ 1 & \omega & \dots & \omega^{n-1} \\ \vdots & \vdots & \dots & \vdots \\ 1 & \omega & \dots & \omega^{n-1} \end{bmatrix}$$

So  $1 + \omega + \omega^2 + \dots + \omega^{n-1} \neq 0$

$$\Rightarrow \frac{1 - \omega^n}{1 - \omega} \neq 0$$

So  $n$  cannot be multiple of 3

So  $n = 55, 56, 58$ .

**Q.47** If  $3^x = 4^{x-1}$ , then  $x =$

- (A)  $\frac{2 \log_3 2}{2 \log_3 2 - 1}$                       (B)  $\frac{2}{2 - \log_2 3}$                       (C)  $\frac{1}{1 - \log_4 3}$                       (D)  $\frac{2 \log_2 3}{2 \log_2 3 - 1}$

**Ans.** [A,B,C]

**Sol.**  $3^x = 4^{x-1}$   
 Take  $\log_3$  both sides  
 $x = (x-1) \log_3 4$   
 $x = (x-1) 2 \log_3 2$   
 $x(1 - 2 \log_3 2) = -2 \log_3 2$   
 $x = \frac{2 \log_3 2}{2 \log_3 2 - 1} = \frac{2}{2 - \log_2 3} = \frac{1}{1 - \log_4 3}$

**Q.48** Let  $w = \frac{\sqrt{3}+1}{2}$  and  $P = \{w^n : n = 1, 2, 3, \dots\}$ . Further  $H_1 = \left\{z \in \mathbb{C} : \operatorname{Re} z > \frac{1}{2}\right\}$  and  $H_2 = \left\{z \in \mathbb{C} : \operatorname{Re} z < -\frac{1}{2}\right\}$ , where  $\mathbb{C}$  is the set of all complex numbers. If  $z_1 \in P \cap H_1$ ,  $z_2 \in P \cap H_2$  and  $O$  represents the origin, then  $\angle z_1 O z_2 =$

(A)  $\frac{\pi}{2}$                       (B)  $\frac{\pi}{6}$                       (C)  $\frac{2\pi}{3}$                       (D)  $\frac{5\pi}{6}$

**Ans.** [C,D]

**Sol.**  $\omega = \frac{\sqrt{3}+i}{2}$

Powers of  $\omega$  lies on a unit circle centred at origin lying at a difference of angle  $\frac{\pi}{6}$

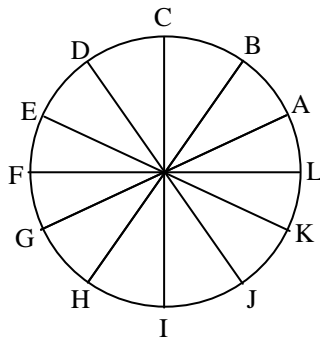

Now for  $H_1$        $\operatorname{Re}(z) > \frac{1}{2}$

So  $P \cap H_1$  can be at point A, L, K

For  $H_2$        $\operatorname{Re}(z) < -\frac{1}{2}$

So  $P \cap H_2$  can be at point E, F, G

So  $\angle z_1 O z_2$  can be  $\frac{2\pi}{3}, \frac{5\pi}{6}$



## SECTION – 2 (Paragraph Type)

This section contains 4 Paragraphs each describing theory, experiment, data etc. Eight questions relate to four paragraph has Only one correct answer among the four choices (A), (B), (C) and (D).

## Paragraph for Questions 49 and 50

Let PQ be a focal chord of the parabola  $y^2 = 4ax$ . The tangents to the parabola at P and Q meet at a point lying on the line  $y = 2x + a$ ,  $a > 0$ .

**Q.49** If chord PQ subtends an angle  $\theta$  at the vertex of  $y^2 = 4ax$ , then  $\tan \theta =$

- (A)  $\frac{2}{3}\sqrt{7}$       (B)  $\frac{-2}{3}\sqrt{7}$       (C)  $\frac{2}{3}\sqrt{5}$       (D)  $\frac{-2}{3}\sqrt{5}$

**Ans.** [D]

**Sol.**

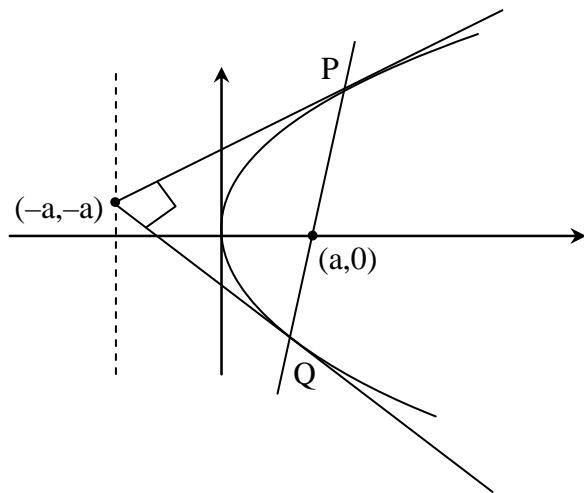

As tangents drawn at end points of focal chord intersect at directrix

So solving  $y = 2x + a$ , and  $x = -a$  we get  $(-a, -a)$

Equation of PQ  $T = 0$

$$(-a)y - 2a(x - a) = 0$$

$$2x + y - 2a = 0$$

Solving it with parabola

$$y^2 - 4ax \left( \frac{2x + y}{2a} \right) = 0$$

$$\Rightarrow y^2 - 4x^2 - 2xy = 0$$

$$\Rightarrow m^2 - 2m - 4 = 0$$

$$m_1 + m_2 = 2, m_1 m_2 = -4$$

$$\tan \theta = \frac{m_1 - m_2}{1 + m_1 m_2} = \frac{\sqrt{(m_1 + m_2)^2 - 4m_1 m_2}}{1 + m_1 m_2} = -\frac{2\sqrt{5}}{3}$$



- Q.50** Length of chord PQ is  
 (A)  $7a$  (B)  $5a$  (C)  $2a$  (D)  $3a$

**Ans.** [B]

**Sol.**  $PQ = \frac{4}{m^2} \sqrt{a(a-mc)(1+m^2)}$   
 $M = -2, c = 2a$   
 $PQ = \frac{4}{4} \sqrt{a(a+4a)(1+4)} = 5a$

**Passage for Question 51 and 52**

Let  $f : [0, 1] \rightarrow \mathbb{R}$  (the set of all real numbers) be a function. Suppose the function  $f$  is twice differentiable,  $f(0) = f(1) = 0$  and satisfies  $f''(x) - 12f'(x) + f(x) \geq e^x, x \in [0, 1]$ .

- Q.51** If the function  $e^{-x}f(x)$  assumes its minimum in the interval  $[0,1]$  at  $x = \frac{1}{4}$ , which of the following is true ?
- (A)  $f'(x) < f(x), \frac{1}{4} < x < \frac{3}{4}$  (B)  $f'(x) > f(x), 0 < x < \frac{1}{4}$   
 (C)  $f'(x) < f(x), 0 < x < \frac{1}{4}$  (D)  $f'(x) < f(x), \frac{3}{4} < x < 1$

**Ans.** [C]

**Sol.** Let  $\phi(x) = e^{-x}f(x); x \in [0,1]$   
 $\phi'(x) = e^{-x}(f'(x) - f(x))$   
 as  $\phi_{\min}(x) = \phi(1/4)$  so  $\phi'(1/4) = 0$   
 and  $\phi''(x) = e^{-x}(f''(x) - 2f'(x) + f(x)) > 0$ ; for  $x \in [0,1]$  (given)  
 so  $\phi'(x)$  increases for  $x \in [0,1]$  and  $\phi'(1/4) = 0$   
 so  $\phi'(x) < 0 \Rightarrow f'(x) < f(x)$  for  $x \in (0, 1/4)$   
 and  $\phi'(x) > 0 \Rightarrow f'(x) > f(x)$  for  $x \in (1/4, 1)$

- Q.52** Which of the following is true for  $0 < x < 1$  ?
- (A)  $0 < f(x) < \infty$  (B)  $-\frac{1}{2} < f(x) < \frac{1}{2}$  (C)  $-\frac{1}{4} < f(x) < 1$  (D)  $-\infty < f(x) < 0$

**Ans.** [D]

**Sol.** From previous questions  
 $\left. \begin{array}{l} \phi_{\min}(x) = \phi(1/4), \phi(0) = f(0) = 0 \\ \& \phi(1) = e^{-1}f(1) = 0 \end{array} \right\} \text{given}$   
 hence  $\phi_{\max} = \phi(0) = \phi(1) = 0$   
 so,  $\phi(x) < 0$ ; for  $x \in (0,1)$   
 $e^{-x}f(x) < 0$ ; for  $x \in (0,1)$   
 $f(x) < 0$ ; for  $x \in (0,1)$

## Passage for Question 53 and 54

A box  $B_1$  contains 1 white ball, 3 red balls and 2 black balls. Another box  $B_2$  contains 2 white balls, 3 red balls and 4 black balls. A third box  $B_3$  contains 3 white balls, 4 red balls and 5 black balls.

**Q.53** If 2 balls are drawn (without replacement) from a randomly selected box and one of the balls is white and the other balls is red, the probability that these 2 balls are drawn from box  $B_2$  is -

- (A)  $\frac{116}{181}$                       (B)  $\frac{126}{181}$                       (C)  $\frac{65}{181}$                       (D)  $\frac{55}{181}$

**Ans.** [D]

**Sol.** Required probability

$$P\left(\frac{B_2}{WR}\right) = \frac{\frac{1}{3} \times \frac{{}^2C_1 \times {}^3C_1}{{}^9C_2}}{\frac{1}{3} \times \frac{{}^1C_1 \times {}^3C_1}{{}^6C_2} + \frac{1}{3} \times \frac{{}^2C_1 \times {}^3C_1}{{}^9C_2} + \frac{1}{3} \times \frac{{}^3C_1 \times {}^4C_1}{{}^{12}C_2}}$$

$$= \frac{\frac{1}{6}}{\frac{1}{5} + \frac{1}{6} + \frac{2}{11}} = \frac{55}{181}$$

**Q.54** If 1 ball is drawn from each of the boxes  $B_1$ ,  $B_2$  and  $B_3$  the probability that all 3 drawn balls are of the same colour is -

- (A)  $\frac{82}{648}$                       (B)  $\frac{90}{648}$                       (C)  $\frac{558}{648}$                       (D)  $\frac{566}{648}$

**Ans.** [A]

**Sol.**  $P(W) + P(R) + P(B)$

$$= \frac{1}{6} \times \frac{2}{9} \times \frac{3}{12} + \frac{3}{6} \times \frac{3}{9} \times \frac{4}{12} + \frac{2}{6} \times \frac{4}{9} \times \frac{5}{12}$$

$$= \frac{6 + 36 + 40}{6 \times 9 \times 12}$$

$$= \frac{82}{648}$$

## Paragraph for Questions 55 and 56

Let  $S = S_1 \cap S_2 \cap S_3$ , where

$$S_1 = \{z \in \mathbb{C} : |z| < 4\}, S_2 = \left\{z \in \mathbb{C} : \operatorname{Im} \left[ \frac{z-1+\sqrt{3}i}{1-\sqrt{3}i} \right] > 0 \right\} \text{ and}$$

$$S_3 = \{z \in \mathbb{C} : \operatorname{Re} z > 0\}$$

**Q.55**  $\min_{z \in S} |1 - 3i - z| =$

(A)  $\frac{2 - \sqrt{3}}{2}$

(B)  $\frac{2 + \sqrt{3}}{2}$

(C)  $\frac{3 - \sqrt{3}}{2}$

(D)  $\frac{3 + \sqrt{3}}{2}$

**Ans.** [C]

**Sol.**  $S_1 : x^2 + y^2 \leq 16$

$$S_2 : \text{Im}g \left( \frac{(x-1) + i(y + \sqrt{3})}{1 - i\sqrt{3}} \right) > 0$$

$$\Rightarrow \sqrt{3}(x-1) + y + \sqrt{3} > 0$$

$$\Rightarrow \sqrt{3}x + y > 0$$

$$S_3 : x > 0$$

Shaded area represents 'S'

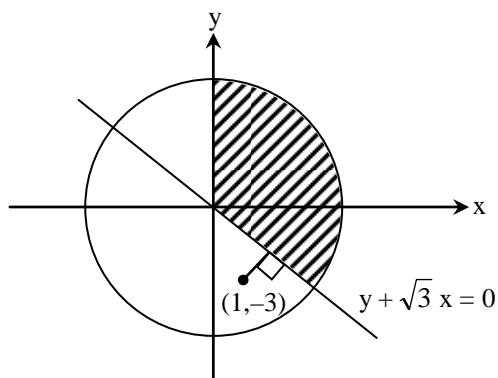

Now  $\min |1 - 3i - z| = \min |z - 1 + 3i|$   
 = minimum distance from  $(1, -3)$

Perpendicular distance of  $(1, -3)$  from line  $y + \sqrt{3}x = 0$

$$= \frac{3 - \sqrt{3}}{2}$$

**Q.56** Area of S =

(A)  $\frac{10\pi}{3}$

(B)  $\frac{20\pi}{3}$

(C)  $\frac{16\pi}{3}$

(D)  $\frac{32\pi}{3}$

**Ans.** [B]

**Sol.** Area of S =  $\frac{1}{2} \times (4)^2 \times \frac{5\pi}{6}$   
 $= \frac{20\pi}{3}$



**Q.57** Match List-I with List-II and select the correct answer using the code given below the lists :

**List – I****List – II**

- (P) Volume of parallelepiped determined by vectors  $\vec{a}$ ,  $\vec{b}$  and  $\vec{c}$  is 2. Then the volume of the parallelepiped determined by vectors  $2(\vec{a} \times \vec{b})$ ,  $3(\vec{b} \times \vec{c})$  and  $(\vec{c} \times \vec{a})$  is (1) 100
- (Q) Volume of parallelepiped determined by vectors  $\vec{a}$ ,  $\vec{b}$  and  $\vec{c}$  is 5. Then the volume of the parallelepiped determined by vectors  $3(\vec{a} + \vec{b})$ ,  $(\vec{b} + \vec{c})$  and  $2(\vec{c} + \vec{a})$  is (2) 30
- (R) Area of a triangle with adjacent sides determined by vectors  $\vec{a}$  and  $\vec{b}$  is 20. Then the area of the triangle with adjacent sides determined by vectors  $(2\vec{a} + 3\vec{b})$  and  $(\vec{a} - \vec{b})$  is (3) 24
- (S) Area of a parallelogram with adjacent sides determined by vectors  $\vec{a}$  and  $\vec{b}$  is 30. Then the area of the parallelogram with adjacent sides determined by vectors  $(\vec{a} + \vec{b})$  and  $\vec{a}$  is (4) 60

**Codes :**

	P	Q	R	S
(A)	4	2	3	1
(B)	2	3	1	4
(C)	3	4	1	2
(D)	1	4	3	2

**Ans.** [C]

- Sol.** (P)  $[\vec{a} \vec{b} \vec{c}] = 2$
- $$2(\vec{a} \times \vec{b}) \cdot [3(\vec{b} \times \vec{c}) \times (\vec{c} \times \vec{a})]$$
- $$= 6(\vec{a} \times \vec{b}) \cdot [\vec{d} \times (\vec{c} \times \vec{a})] \quad (\text{let } \vec{d} = \vec{b} \times \vec{c})$$
- $$= 6(\vec{a} \times \vec{b}) \cdot [(\vec{d} \cdot \vec{a})\vec{c} - (\vec{d} \cdot \vec{c})\vec{a}]$$
- $$= 6[\vec{a} \vec{b} \vec{c}](\vec{d} \cdot \vec{a}) - 6[\vec{a} \vec{b} \vec{a}](\vec{d} \cdot \vec{c})$$
- $$= 6[\vec{a} \vec{b} \vec{c}]^2 = 6 \times 4 = 24$$
- (Q)  $[\vec{a} \vec{b} \vec{c}] = 5$
- $$3(\vec{a} + \vec{b}) \cdot [(\vec{b} + \vec{c}) \times 2(\vec{c} + \vec{a})]$$
- $$6(\vec{a} + \vec{b}) \cdot [(\vec{b} \times \vec{c}) + (\vec{b} \times \vec{a}) + (\vec{c} \times \vec{c}) + (\vec{c} \times \vec{a})]$$
- $$= 6([\vec{a} \vec{b} \vec{c}]) + [\vec{a} \vec{b} \vec{c}] = 12[\vec{a} \vec{b} \vec{c}] = 12 \times 5 = 60$$

$$(R) \quad \frac{1}{2} |\vec{a} \times \vec{b}| = 20$$

$$\begin{aligned} \text{then } & \frac{1}{2} |(2\vec{a} + 3\vec{b}) \times (\vec{a} - \vec{b})| \\ &= \frac{1}{2} |-2(\vec{a} \times \vec{b}) + 3(\vec{b} \times \vec{a})| \\ &= \frac{1}{2} |5(\vec{b} \times \vec{a})| = 5 \times 20 = 100 \end{aligned}$$

$$(S) \quad |\vec{a} \times \vec{b}| = 30$$

$$\begin{aligned} \text{Then } & |(\vec{a} + \vec{b}) \times \vec{a}| \\ &= |\vec{a} \times \vec{a} + \vec{b} \times \vec{a}| \\ &= 30 \end{aligned}$$

**Q.58** Consider the lines  $L_1 : \frac{x-1}{2} = \frac{y}{-1} = \frac{z+3}{1}$ ,  $L_2 : \frac{x-4}{1} = \frac{y+3}{1} = \frac{z+3}{2}$  and the planes  $P_1 : 7x + y + 2z = 3$ ,  $P_2 : 3x + 5y - 6z = 4$ . Let  $ax + by + cz = d$  be the equation of the plane passing through the point of intersection of lines  $L_1$  and  $L_2$ , and perpendicular to planes  $P_1$  and  $P_2$ .

Match List-I with List-II and select the correct answer using the code given below the lists :

**List-I****List-II**

(P) $a =$	(1) 13
(Q) $b =$	(2) -3
(R) $c =$	(3) 1
(S) $d =$	(4) -2

**Codes :**

	P	Q	R	S
(A)	3	2	4	1
(B)	1	3	4	2
(C)	3	2	1	4
(D)	2	4	1	3

**Ans.** [A]

**Sol.** Any point on line  $L_1$   $(2\lambda + 1, -\lambda, \lambda - 3)$   
 Any point on line  $L_2$   $(\mu + 4, \mu - 3, 2\mu - 3)$   
 for point of intersection of  $L_1$  &  $L_2$   
 $2\lambda + 1 = \mu + 4, -\lambda = \mu - 3, \lambda - 3 = 2\mu - 3$   
 so  $\lambda = 2, \mu = 1$   
 so point of intersection is  $(5, -2, -1)$   
 required plane is perpendicular to both given planes so  
 $7a + b + 2c = 0$  .....(i)  
 $3a + 5b - 6c = 0$  .....(ii)  
 From (i) & (ii)



$$\frac{a}{-6-10} = \frac{-b}{-42-6} = \frac{c}{35-3}$$

$$\frac{a}{-1} = \frac{b}{3} = \frac{c}{2}$$

So required equation of plane is

$$-1(x-5) + 3(y+2) + 2(z+1) = 0$$

$$-x + 5 + 3y + 6 + 2z + 2 = 0$$

$$x - 3y - 2z = 13$$

so  $a = 1$ ,  $b = -3$ ,  $c = -2$ ,  $d = 13$

**Q.59** Match List-I with List-II and select the correct answer using the code given below the lists :

**List - I**

**List - II**

(P)  $\left( \frac{1}{y^2} \left( \frac{\cos(\tan^{-1} y) + y \sin(\tan^{-1} y)^2}{\cot(\sin^{-1} y) + \tan(\sin^{-1} y)} \right) + y^4 \right)^{1/2}$  takes value (1)  $\frac{1}{2} \sqrt{\frac{5}{3}}$

(Q) If  $\cos x + \cos y + \cos z = 0 = \sin x + \sin y + \sin z$  then possible value of  $\cos \frac{x-y}{2}$  is (2)  $\sqrt{2}$

(R) If  $\cos \left( \frac{\pi}{4} - x \right) \cos 2x + \sin x \sin 2x \sec x$  (3)  $\frac{1}{2}$

$= \cos x \sin 2x \sec x + \cos \left( \frac{\pi}{4} + x \right) \cos 2x$  then possible value of  $\sec x$  is

(S) If  $\cot(\sin^{-1} \sqrt{1-x^2}) = \sin(\tan^{-1}(x\sqrt{6}))$ ,  $x \neq 0$ , then possible value of  $x$  is (4) 1

**Codes :**

	P	Q	R	S
(A)	4	3	1	2
(B)	4	3	2	1
(C)	3	4	2	1
(D)	3	4	1	2

**Ans. [B]**

**Sol.** P :  $\left[ \frac{1}{y^2} \left[ \frac{\frac{1}{\sqrt{1+y^2}} + \frac{y \cdot y}{\sqrt{1+y^2}}}{\frac{\sqrt{1+y^2}}{y} + \frac{y}{\sqrt{1-y^2}}} \right] + y^4 \right]^{1/2}$

$$\left[ \frac{1}{y^2} \left( \frac{\sqrt{1+y^2}}{1} \cdot y \sqrt{1+y^2} + y^4 \right) \right]^{1/2} = [1 - y^4 + y^4]^{1/2} = 1$$

$$Q : \cos x + \cos y = -\cos z \quad \dots\dots(i)$$

$$\sin x + \sin y = -\sin z \quad \dots\dots(ii)$$

square & add equation (i) & (ii)

$$2 + 2 \cos(x - y) = 1$$

$$\cos(x - y) = \frac{-1}{2}$$

$$2 \cos^2\left(\frac{x - y}{2}\right) - 1 = \frac{-1}{2}$$

$$\cos^2\left(\frac{x - y}{2}\right) = \frac{1}{4}$$

$$\cos \frac{1}{4} = \pm \frac{1}{2}$$

$$R : \left( \cos\left(\frac{\pi}{4} - x\right) - \cos\left(\frac{\pi}{4} + x\right) \right) \cos 2x = \sin 2x [\cot x - \tan x]$$

$$\sin \frac{\pi}{4} \sin x \cdot \cos 2x = \sin 2x \times 2 \cot 2x$$

$$\frac{\sin x}{\sqrt{2}} = 1 \Rightarrow \sin x = \sqrt{2} \text{ in possible}$$

$$\text{or } \cos 2x = 0$$

$$\cos^2 x = \frac{1}{2}$$

$$\Rightarrow \cos x = \frac{1}{\sqrt{2}}$$

$$\sin x = \sqrt{2}$$

$$S : \cot(\sin^{-1} \sqrt{1 - x^2}) = \sin \tan^{-1}(x\sqrt{6})$$

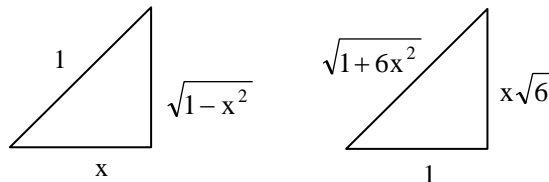

$$\frac{x}{\sqrt{1 - x^2}} = \frac{x\sqrt{6}}{\sqrt{1 + 6x^2}}$$

$x = 0$  not possible

$$\therefore \frac{1}{\sqrt{1 - x^2}} = \frac{\sqrt{6}}{\sqrt{1 + 6x^2}}$$

$$1 + 6x^2 = 6 - 6x^2$$

$$12x^2 = 5$$

$$x = \sqrt{\frac{5}{12}} = \frac{1}{2} \sqrt{\frac{5}{3}}$$





**Q.60** A line  $L : y = mx + 3$  meets  $y$ -axis at  $E (0, 3)$  and the arc of the parabola  $y^2 = 16x, 0 \leq y \leq 6$  at the point  $F(x_0, y_0)$ . The tangent to the parabola at  $F(x_0, y_0)$  intersects the  $y$ -axis at  $G(0, y_1)$ . The slope  $m$  of the line  $L$  is chosen such that the area of the triangle  $EFG$  has a local maximum.

Match List-I with List-II and select the correct answer using the code given below the lists :

- | List-I                              | List-II           |
|-------------------------------------|-------------------|
| (P) $m =$                           | (1) $\frac{1}{2}$ |
| (Q) Maximum area of $\Delta EFG$ is | (2) 4             |
| (R) $y_0 =$                         | (3) 2             |
| (S) $y_1 =$                         | (4) 1             |

**Codes :**

	P	Q	R	S
(A)	4	1	2	3
(B)	3	4	1	2
(C)	1	3	2	4
(D)	1	3	4	2

**Ans.**  
**Sol.** [A]

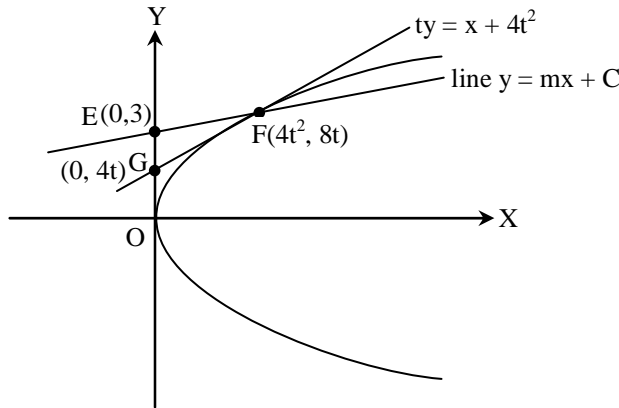

$$\text{Area of } \Delta EFG = \frac{1}{2} \begin{vmatrix} 1 & 1 & 1 \\ 0 & 0 & 4t^2 \\ 3 & 4t & 8t \end{vmatrix} = 24t(-2t + 1)$$

$t = 0$                        $t = 1/2$   
not possible              local point of maxima  
so point  $E(0, 3)$

$F(1, 4)$   
 $G(0, 2)$

$$\text{Slope} = m = \frac{4-3}{1-0} = 1$$

$y_0 = 4$   
 $y_1 = 2$

$$\text{Area} = \frac{1}{2} \begin{vmatrix} 1 & 1 & 1 \\ 0 & 1 & 0 \\ 3 & 4 & 2 \end{vmatrix} = \frac{1}{2} [1(2) + 3(-1)] = -\frac{1}{2}$$

$$\text{Area} = \frac{1}{2} \text{unit}^2$$