



## JEE Main Online Exam 2023

### Questions & Solution

13<sup>th</sup> April 2023 | Evening

#### MATHEMATICS

**Section-A: Multiple Choice Questions:** This section contains 20 multiple choice questions. Each question has 4 choices (1), (2), (3) and (4), out of which **ONLY ONE** is correct.

**Q.1** Let  $\alpha, \beta$  be the roots of the equation  $x^2 - \sqrt{2}x + 2 = 0$ . Then  $\alpha^{14} + \beta^{14}$  is equal to :  
(1) -64 (2)  $-64\sqrt{2}$  (3) -128 (4)  $-128\sqrt{2}$

**Ans.** [3]

**Sol.**  $x^2 - \sqrt{2}x + 2 = 0 \begin{cases} \alpha \\ \beta \end{cases}$

$$x = \frac{\sqrt{2} \pm i\sqrt{6}}{2}$$

$$\text{Let } \alpha = \frac{1+i\sqrt{3}}{\sqrt{2}}, \beta = \frac{1-\sqrt{3}i}{\sqrt{2}} = \sqrt{2}\omega^2 = \sqrt{2}\omega$$

$$\alpha^{14} = 2^7\omega^2, \beta^{14} = 2^7\omega$$

$$\therefore \alpha^{14} + \beta^{14} = 2^7(-1) = -2^7$$

**Q.2** The plane, passing through the points (0, -1, 2) and (-1, 2, 1) and parallel to the line passing through (5, 1, -7) and (1, -1, -1), also passes through the point :

(1) (-2, 5, 0) (2) (1, -2, 1) (3) (2, 0, 1) (4) (0, 5, -2)

**Ans.** [1]

**Sol.** Let A(0, -1, 2) & B(-1, 2, 1)

So, normal vector to the plane

$$\vec{n} = \begin{vmatrix} \hat{i} & \hat{j} & \hat{k} \\ -1 & 3 & -1 \\ -4 & -2 & 6 \end{vmatrix} = \hat{i}(16) - \hat{j}(-10) + \hat{k}(14)$$

$$= 16\hat{i} + 10\hat{j} + 14\hat{k}$$

$\therefore$  Equation of plane

$$16(x - 0) + 10(y + 1) + 14(z - 2) = 0$$

$$\Rightarrow 8x + 5y + 7z = 9$$

$\therefore$  Option (1) is correct

**Q.3** The statement  $(p \wedge (\sim q)) \vee ((\sim p) \wedge q) \vee ((\sim p) \wedge (\sim q))$  is equivalent to \_\_\_\_\_

(1)  $(\sim p) \vee q$  (2)  $(\sim p) \vee (\sim q)$  (3)  $p \vee (\sim q)$  (4)  $p \vee q$

**Ans.** [2]

**Sol.**  $(p \wedge (\sim q)) \vee ((\sim p) \wedge q) \vee ((\sim p) \wedge (\sim q))$

$$= (\sim p \wedge (q \vee \sim q)) \vee (p \wedge \sim q)$$

$$= \sim p \vee (p \wedge \sim q)$$

$$= (\sim p \vee p) \wedge (\sim p \vee \sim q)$$

$$= \sim p \vee \sim q$$

**Q.4** Let the centre of a circle C be  $(\alpha, \beta)$  and its radius  $r < 8$ . Let  $3x + 4y = 24$  and  $3x - 4y = 32$  be two tangents and  $4x + 3y = 1$  be a normal to C. Then  $(\alpha - \beta + r)$  is equal to :

- (1) 7 (2) 5 (3) 6 (4) 9

**Ans.** [1]

**Sol.**  $\therefore (\alpha, \beta)$  lies on  $4x + 3y = 1$

$$\therefore 4\alpha + 3\beta = 1 \quad \dots(i)$$

$$\text{and } \left| \frac{3\alpha + 4\beta - 24}{5} \right| = \left| \frac{3\alpha - 4\beta - 32}{5} \right|$$

Take (+ve)

$$3\alpha + 4\beta - 24 = 3\alpha - 4\beta - 32$$

$$\therefore 8\beta = -8 \Rightarrow \beta = -1$$

So  $\alpha = 1$  By equation (i)

$$\text{And } r = \left| \frac{3 - 4 - 24}{5} \right| = 5 < 8$$

Take (-ve)

$$3\alpha + 4\beta - 24 = -3\alpha + 4\beta + 32$$

$$6\alpha = 56 \Rightarrow \alpha = \frac{56}{6} \text{ and } \beta = \frac{1}{3} \left( 1 - \frac{4 \times 28}{3} \right)$$

For then  $r > 8$

$$\therefore r = 5, \alpha = 1, \beta = -1$$

$$\therefore \alpha - \beta + r = 7$$

**Q.5** The coefficient of  $x^5$  in the expansion of  $\left( 2x^3 - \frac{1}{3x^2} \right)^5$  is :

- (1)  $\frac{80}{9}$  (2) 9 (3) 8 (4)  $\frac{26}{3}$

**Ans.** [1]

**Sol.**  $T_{r+1} = {}^5C_r (2x^3)^{5-r} \left( \frac{-1}{3x^2} \right)^r$

$$15 - 3r - 2r = 5$$

$$\Rightarrow r = 2$$

$$\text{Coefficient} = {}^5C_2 (2)^3 \left( \frac{1}{9} \right) = \frac{80}{9}$$

**Q.6** All words, with or without meaning, are made using all the letters of the word MONDAY. These words are written as in a dictionary with serial numbers. The serial number of the word MONDAY is

- (1) 327 (2) 328 (3) 324 (4) 326

**Ans.** [1]

**Sol.**

3 5 4 2 1 6

M O N D A Y

2 3 2 1 0 0

5! 4! 3! 2! 1! 0!

$$\therefore \text{Rank} = (2 \times 5! + 3 \times 4! + 2 \times 3! + 1 \times 2!) + 1 \\ = 240 + 72 + 12 + 2 + 1 = 327$$

Q.7 The value of  $\frac{e^{-\frac{\pi}{4}} + \int_0^{\frac{\pi}{4}} e^{-x} \tan^{50} x dx}{\int_0^{\frac{\pi}{4}} e^{-x} (\tan^{49} x + \tan^{51} x) dx}$  is :

- (1) 51                                      (2) 50                                      (3) 25                                      (4) 49

Ans. [2]

Sol.

$$\frac{e^{-\frac{\pi}{4}} + \int_0^{\frac{\pi}{4}} e^{-x} \tan^{50} x dx}{\int_0^{\frac{\pi}{4}} e^{-x} (\tan^{49} x + \sec^2 x) dx}$$

$$= \frac{e^{-\frac{\pi}{4}} + \int_0^{\frac{\pi}{4}} e^{-x} \tan^{50} x dx}{\left( \left( \frac{e^{-x} \tan^{50} x}{50} \right)_0^{\frac{\pi}{4}} + \int_0^{\frac{\pi}{4}} \frac{e^{-x} \tan^{50} x}{50} dx \right)} = 50$$

Q.8 Let for a triangle ABC,

$$\vec{AB} = -2\hat{i} + \hat{j} + 3\hat{k}$$

$$\vec{CB} = \alpha\hat{i} + \beta\hat{j} + \gamma\hat{k}$$

$$\vec{CA} = 4\hat{i} + 3\hat{j} + \delta\hat{k}$$

If  $\delta > 0$  and the area of the triangle ABC is  $5\sqrt{6}$ ,

then  $\vec{CB} \cdot \vec{CA}$  is equal to :

- (1) 60                                      (2) 54                                      (3) 108                                      (4) 120

Ans. [1]

Sol.

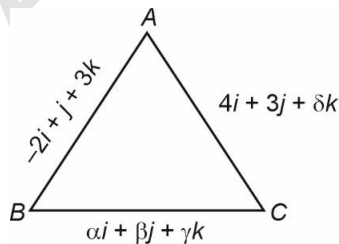

$$CA + AB = CB$$

$$+2\hat{i} + 4\hat{j} + (\delta + 3)\hat{k} = \alpha\hat{i} + \beta\hat{j} + \gamma\hat{k}$$

$$\Rightarrow \alpha = +2, \beta = 4, \gamma = \delta + 3$$

$$\text{Area} = \frac{1}{2} |\vec{AB} \times \vec{BC}| = \left| \frac{1}{2} \begin{vmatrix} i & j & k \\ -2 & 1 & 3 \\ +2 & 4 & \gamma \end{vmatrix} \right| = 5\sqrt{6} = (\gamma - 12)^2 + (6 + 2\gamma)^2 + 100 = (10\sqrt{6})^2$$

$$\Rightarrow 5\gamma^2 = 320$$

$$\gamma^2 = 64$$

$$\gamma = 8$$

$$\delta = 5$$

$$\vec{CB} \cdot \vec{CA} = (2i + 4j + 8k) \cdot (4i + 3j + 5k) = 8 + 12 + 40 = 60$$

**Q.9** Let  $a_1, a_2, a_3, \dots$  be a G.P. of increasing positive numbers. Let the sum of its 6<sup>th</sup> and 8<sup>th</sup> terms be 2 and the product of its 3<sup>rd</sup> and 5<sup>th</sup> terms be  $\frac{1}{9}$ . Then  $6(a_2 + a_4)(a_4 + a_6)$  is equal to :

(1) 3

(2)  $3\sqrt{3}$

(3) 2

(4)  $2\sqrt{2}$

**Ans.**

[1]

**Sol.**

$$a_6 + a_8 = 2$$

$$\Rightarrow ar^5 + ar^7 = 2 \quad \dots(i)$$

$$a_3 \cdot a_5 = \frac{1}{9} \Rightarrow a^2 \cdot r^2 \cdot r^4 = \frac{1}{9}$$

$$\Rightarrow ar^3 = \frac{1}{3}$$

$$\frac{r^2}{3} + \frac{r^4}{3} = 2$$

$$\Rightarrow r^4 + r^2 = 6$$

$$\Rightarrow (r^2 + 3)(r^2 - 2) = 0$$

$$\Rightarrow r^2 = 2$$

$$\therefore ar \cdot 2 = \frac{1}{3} \Rightarrow ar = \frac{1}{6}$$

$$\text{Now, } 6(a_2 + a_4)(a_4 + a_6) = 6(ar + ar^3)(ar^3 + ar^5)$$

$$= 6 \left( \frac{1}{6} + \frac{1}{3} \right) \left( \frac{1}{3} + \frac{2}{3} \right) = 6 \cdot \frac{1}{2} \cdot 1 = 3$$

**Q.10** The range of  $f(x) = 4 \sin^{-1} \left( \frac{x^2}{x^2 + 1} \right)$  is :

(1)  $[0, 2\pi]$

(2)  $[0, \pi]$

(3)  $[0, 2\pi)$

(4)  $[0, \pi)$

**Ans.**

[3]

**Sol.**

$$\frac{x^2}{1+x^2} = 1 - \frac{1}{1+x^2} < 1$$

$$\therefore 0 \leq \frac{x^2}{1+x^2} < 1$$

$$\Rightarrow 0 \leq \sin^{-1} \left( \frac{x^2}{1+x^2} \right) < \frac{\pi}{2}$$

$$\Rightarrow 0 \leq 4 \sin^{-1} \left( \frac{x^2}{1+x^2} \right) < 2\pi$$

$\therefore$  Option (3) is correct.

- Q.11** The random variable  $X$  follows binomial distribution  $B(n, p)$ , for which the difference of the mean and the variance is 1.  
 If  $2P(X = 2) = 3P(X = 1)$ , then  $n^2P(X > 1)$  is equal to :  
 (1) 15 (2) 11 (3) 12 (4) 16

**Ans.** [2]

**Sol.**

$$\begin{aligned} np - npq &= 1 \\ \Rightarrow np(1 - q) &= 1 \\ \Rightarrow np^2 &= 1 \\ 2P(X = 2) &= 3P(X = 1) \\ 2 \cdot {}^nC_2 p^2 q^{n-2} &= 3 \cdot {}^nC_1 p \cdot q^{n-1} \\ \Rightarrow 2 \cdot \frac{n(n-1)}{2} \cdot p &= 3 \cdot n \cdot q \\ \Rightarrow (n-1)p &= 3(1-p) \\ \Rightarrow \left(\frac{1}{p^2} - 1\right)p &= 3(1-p) \\ \Rightarrow \frac{(1-p)(1+p)}{p} &= 3(1-p) \\ \Rightarrow 1+p &= 3p \\ \Rightarrow p &= \frac{1}{2} \\ \therefore n &= 4 \end{aligned}$$

$$n^2P(X > 1) = n^2(1 - P(X = 1) - P(X = 0)) = 16 \left(1 - {}^4C_1 \left(\frac{1}{2}\right)^4 - \left(\frac{1}{2}\right)^4\right) = 11$$

Option (2) is correct.

- Q.12** The line, that is coplanar to the line  $\frac{x+3}{-3} = \frac{y-1}{1} = \frac{z-5}{5}$  is :

$$\begin{aligned} (1) \frac{x+1}{-1} = \frac{y-2}{2} = \frac{z-5}{4} & \qquad (2) \frac{x+1}{-1} = \frac{y-2}{2} = \frac{z-5}{5} \\ (3) \frac{x-1}{-1} = \frac{y-2}{2} = \frac{z-5}{5} & \qquad (4) \frac{x+1}{1} = \frac{y-2}{2} = \frac{z-5}{5} \end{aligned}$$

**Ans.** [2]

**Sol.** Given line :  $\frac{x+3}{-3} = \frac{y-1}{1} = \frac{z-5}{5}$

No line in given options is parallel to given line.

$\therefore$  If two lines are coplanar, then distance between them must be zero.

Among the given option, only option (2) satisfies above condition.

$$\begin{vmatrix} -2 & -1 & 0 \\ -3 & 1 & 5 \\ -1 & 2 & 5 \end{vmatrix} \\ = -2(-5) + 1(-15 + 5) = 0. \\ \therefore \text{Option (2) is correct.}$$

- Q.13** The area of the region  $x, y : x^2 \leq y \leq |x^2 - 4|, y \geq 1$  is :

$$(1) \frac{4}{3}(4\sqrt{2} - 1) \qquad (2) \frac{4}{3}(4\sqrt{2} + 1) \qquad (3) \frac{3}{4}(4\sqrt{2} + 1) \qquad (4) \frac{3}{4}(4\sqrt{2} - 1)$$

**Ans.** [1]

Sol.

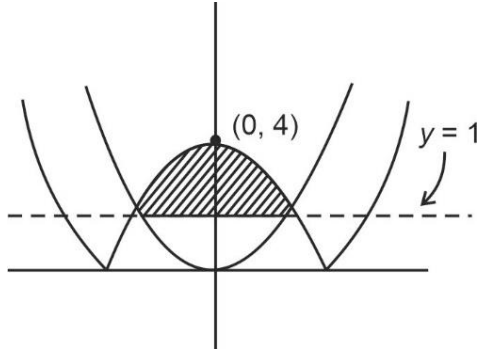

$$\begin{aligned} \text{Required area} &= 2 \left[ \int_1^2 \sqrt{y} \, dy + \int_4^2 \sqrt{4-y} \, dy \right] \\ &= 2 \left[ \left. \frac{y^{3/2}}{3/2} \right|_1^2 - \left. \frac{2(4-y)^{3/2}}{3} \right|_2^4 \right] = \frac{4}{3}(4\sqrt{2} - 1) \end{aligned}$$

**Q.14** Let  $|\vec{a}| = 2$ ,  $|\vec{b}| = 3$  and the angle between the vectors  $\vec{a}$  and  $\vec{b}$  be  $\frac{\pi}{4}$ . Then

$|(\vec{a} + 2\vec{b}) \times (2\vec{a} - 3\vec{b})|^2$  is equal to :

(1) 441

(2) 482

(3) 841

(4) 882

**Ans.** [4]

**Sol.**  $|\vec{a}| = 2$

$|\vec{b}| = 4$

$\vec{a} \cdot \vec{b} = \frac{\pi}{4}$

$|(\vec{a} + 2\vec{b}) \times (2\vec{a} - 3\vec{b})|^2$

$= |-3(\vec{a} \times \vec{b}) + 4(\vec{b} \times \vec{a})|^2$

$= |7(\vec{b} \times \vec{a})|^2$

$= 49|\vec{a}|^2 |\vec{b}|^2 \sin^2 \frac{\pi}{4}$

$49 \times 4 \times 9 \times \frac{1}{2}$

$= 882$

**Q.15** If the system of equations

$$2x + y - z = 5$$

$$2x - 5y + \lambda z = \mu$$

$$x + 2y - 5z = 7$$

has infinitely many solutions, then

$(\lambda + \mu)^2 + (\lambda - \mu)^2$  is equal to :

(1) 904

(2) 916

(3) 912

(4) 920

**Ans.** [2]

**Sol.**  $2x + y - z = 5$

$2x - 5y + \lambda z = \mu$

$x + 2y - 5z = 7$

For infinite solution  $\Delta = 0 = \Delta_1 = \Delta_2 = \Delta_3$ 

$$\Delta = \begin{vmatrix} 2 & 1 & -1 \\ 2 & -5 & \lambda \\ 1 & 2 & -5 \end{vmatrix} = 0$$

$51 - 3\lambda = 0 \Rightarrow \lambda = 17$

$$\Delta_3 = \begin{vmatrix} 5 & 2 & 1 \\ \mu & 2 & -5 \\ 7 & 1 & 2 \end{vmatrix} = 0$$

$-3(\mu + 3)$

$\mu = -13$

Now  $(\lambda + \mu)^2 + (\lambda - \mu)^2$

$(17 + 13)^2 + (17 - 13)^2$

$900 + 16 = 916$

**Q.16** Let  $(\alpha, \beta)$  be the centroid of the triangle formed by the lines  $15x - y = 82$ ,  $6x - 5y = -4$  and  $9x + 4y = 17$ .Then  $\alpha + 2\beta$  and  $2\alpha - \beta$  are the roots of the equation :

(1)  $x^2 - 7x + 12 = 0$

(2)  $x^2 - 14x + 48 = 0$

(3)  $x^2 - 13x + 42 = 0$

(4)  $x^2 - 10x + 25 = 0$

**Ans.** [3]

**Sol.**  $15x - y = 82$

$6x - 5y = -4$

$9x + 4y = 17$

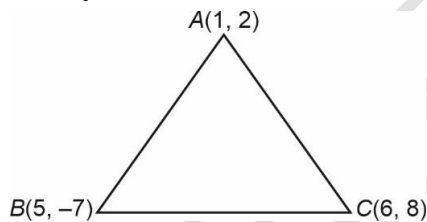

$$(\alpha, \beta) = \left( \frac{1+5+6}{3}, \frac{2-7+8}{3} \right) \equiv (4, 1)$$

$\alpha + 2\beta = 6$  and  $2\alpha - \beta = 7$

Equation  $x^2 - 13x + 42 = 0$

**Q.17** Let  $S = \{z \in \mathbb{C} : \bar{z} = i(z^2 + \text{Re}(\bar{z}))\}$ . Then  $\sum_{z \in S} |z|^2$  is equal to :

(1)  $\frac{5}{2}$

(2) 4

(3)  $\frac{7}{2}$

(4) 3

**Ans.** [2]

**Sol.** Let  $z = x + iy$

$\Rightarrow \bar{z} = i(z^2 + \text{Re}(\bar{z}))$

$\Rightarrow x - iy = i(x^2 - y^2 + 2ixy + x)$

$x - iy = i(x^2 - y^2 + x) - 2xy$

$x = -2xy \Rightarrow x(2y + 1) = 0$

$$\Rightarrow x = 0, y = \frac{-1}{2} \quad \dots(i)$$

$$-y = x^2 - y^2 + x \quad \dots(ii)$$

Case (I)  $x = 0$

$$(ii) \Rightarrow -y = -y^2 \Rightarrow y^2 - y = 0 \Rightarrow y = 0, 1$$

$z = 0, i$

$$\text{Case (II) } y = \frac{-1}{2}$$

$$(ii) \Rightarrow \frac{1}{2} = x^2 - \frac{1}{4} + x \Rightarrow x^2 + x - \frac{3}{4} = 0$$

$$4x^2 + 4x - 3 = 0 \Rightarrow (2x - 1)(2x + 3) = 0$$

$$\Rightarrow x = \frac{1}{2}, \frac{-3}{2}$$

$$x = \frac{1}{2} - \frac{1}{2}i, \frac{-3}{2} - \frac{-1}{2}i$$

$$\sum |z|^2 = 0 + 1 + \frac{1}{2} + \frac{5}{2} = 4$$

**Q.18** If  $\lim_{x \rightarrow 0} \frac{e^{ax} - \cos(bx) - \frac{cxe^{-cx}}{2}}{1 - \cos(2x)} = 17$ , then  $5a^2 + b^2$  is equal to :

(1) 64

(2) 72

(3) 68

(4) 76

**Ans.** [3]

**Sol.**  $\lim_{x \rightarrow 0} \frac{e^{ax} - \cos(bx) - \frac{cx}{2} e^{-cx}}{1 - \cos(2x)} = 17$ ,

$$\lim_{x \rightarrow 0} \frac{\left(1 + ax + \frac{(ax)^2}{2!} + \dots\right) - \left(1 - \frac{(bx)^2}{2!} + \dots\right) - \frac{cx}{2} \left(1 - (cx) + \frac{(cx)^2}{2!}\right)}{\left(\frac{1 - \cos 2x}{(2x)^2}\right) \times 4x^2}$$

$$\lim_{x \rightarrow 0} \frac{\left(a - \frac{c}{2}\right)x + \left(\frac{a^2 + b^2 + c^2}{2}\right)x^2 + \dots}{\frac{1}{2} \times 4x^2}$$

$$a - \frac{c}{2} = 0 \Rightarrow c = 2a$$

$$\frac{a^2 + b^2 + c^2}{4} = 17$$

$$a^2 + b^2 + 4a^2 = 68$$

$$5a^2 + b^2 = 68$$

**Q.19** Let N be the foot of perpendicular from the point P(1, -2, 3) on the line passing through the points (4, 5, 8) and (1, -7, 5). Then the distance of N from the plane  $2x - 2y + z + 5 = 0$  is :

(1) 8

(2) 6

(3) 9

(4) 7

**Ans.** [d]



**Sol.** Dr of line L (1, 4, 1)  
Line L :  $\frac{x-1}{1} = \frac{y+7}{4} = \frac{z-5}{1} = r$   
Point N  $\equiv (r+1, 4r-7, r+5)$   
P  $\equiv (1, -2, 3)$   
Drs of PN (r, 4r-5, r+2)  
PN  $\perp$  L  $\Rightarrow r+4(4r-5) + (r+2) = 0$   
 $\Rightarrow r = 1$   
N  $\equiv (2, -3, 6)$   
Distance of N(2, -3, 6) from  $2x - 2y + z + 5 = 0$   
 $\frac{|4+6+6+5|}{\sqrt{4+4+1}} = 7$

**Q.20** Let for  $A = \begin{bmatrix} 1 & 2 & 3 \\ \alpha & 3 & 1 \\ 1 & 1 & 2 \end{bmatrix}$ ,  $|A| = 2$ . If  $|2 \text{adj}(2 \text{adj}(2A))| = 32^n$ , then  $3n + \alpha$  is equal to :

(1) 9

(2) 11

(3) 12

(4) 10

**Ans.** [2]

**Sol.**  $A = \begin{bmatrix} 1 & 2 & 3 \\ \alpha & 3 & 1 \\ 1 & 1 & 2 \end{bmatrix}$

$$|A| = 2$$

$$\Rightarrow -\alpha - 2 = 2$$

$$\Rightarrow \alpha = -4$$

$$|2 \text{adj}(2 \text{adj}(2A))| = 32^n$$

$$= 2^3 |\text{adj}(2 \text{adj}(2A))|$$

$$= 2^3 |\text{adj}(\text{adj}(2A))|$$

$$= 2^3 \cdot (4)^3 |\text{adj}(2A)|$$

$$= 2^9 |2A|^{(2)^2}$$

$$= 2^9 \cdot |2A|^4$$

$$= 2^9 \cdot 2^{12} |A|^4$$

$$= 2^{21} \cdot 2^4 = 2^{25} (32)^n = (2)^{5n}$$

$$\therefore n = 5$$

$$\Rightarrow 3n + \alpha = 15 - 4 = 11$$

**Section-B: Numerical Value Type Questions:** This section contains 10 questions. In Section B, attempt any five questions out of 10. The answer to each question is a **NUMERICAL VALUE**. For each question, enter the correct numerical value (in decimal notation, truncated/rounded-off to the second decimal place; e.g. 06.25, 07.00, -00.33, -00.30, 30.27, -27.30) using the mouse and the on-screen virtual numeric keypad in the place designated to enter the answer..

**Q.21** Let  $f_n = \int_0^{\frac{\pi}{2}} \left( \sum_{k=1}^n \sin^{k-1} x \right) \left( \sum_{k=1}^n (2k-1) \sin^{k-1} x \right) \cos x \, dx$ ,  $n \in \mathbb{N}$ . Then  $f_{21} - f_{20}$  is equal to \_\_\_\_\_.

**Ans.** [41]

**Sol.**  $f_n = \int_0^{\frac{\pi}{2}} \left( \sum_{k=1}^n \sin^{k-1} x \right) \left( \sum_{k=1}^n (2k-1) \sin^{k-1} x \right) \cos x \, dx$

put  $\sin x = t$

$\cos x \, dx = dt$

$$f_n = \int_0^1 \left( \sum_{k=1}^n (t)^{k-1} \right) \left( \sum_{k=1}^n (2k-1)(t)^{k-1} \right) dt$$

$$f_{21} - f_{20} = \int_0^1 \left( \sum_{k=1}^{21} (t)^{k-1} \right) \left( \sum_{k=1}^{21} (2k-1)(t)^{k-1} \right) - \left( \sum_{k=1}^{20} (t)^{k-1} \right) \left( \sum_{k=1}^{20} (2k-1)(t)^{k-1} \right) dt$$

$$= \int_0^1 (1+t+t^2+\dots+t^{19})(41)t^{20} + (1+3t+5t^2+\dots+41t^{20})t^{20} dt$$

$$= \left( \frac{1}{21} + \frac{1}{22} + \dots + \frac{1}{40} \right) 41 + \left( \frac{1}{21} + \frac{3}{22} + \dots + \frac{39}{40} + \frac{41}{41} \right)$$

$$= \left[ \frac{42}{21} + \frac{44}{22} + \frac{46}{23} + \dots + \frac{80}{40} + \frac{41}{41} \right] = 40 + 1 = 41$$

**Q.22** Let  $A = \{-4, -3, -2, 0, 1, 3, 4\}$  and  $R = \{(a, b) \in A \times A : b = |a| \text{ or } b^2 = a + 1\}$  be a relation on  $A$ . Then the minimum number of elements, that must be added to the relation  $R$  so that it becomes reflexive and symmetric, is \_\_\_\_\_.

**Ans.** [7]

**Sol.**  $A = \{-4, -3, -2, 0, 1, 3, 4\}$

$R = \{(-4, 4), (-3, 3), (0, 0), (1, 1), (3, 3), (4, 4), (0, 1), (3, 2)\}$

Relation to be reflexive  $(a, a) \in R \forall a \in A$

$\Rightarrow (-4, -4), (-3, -3), (-2, -2)$  also should be added in  $R$ .

Relation to be symmetric if  $(a, b) \in R$ , then  $(b, a) \in R \forall a, b \in A$

$\Rightarrow (4, -4), (3, -3), (1, 0), (-2, 3)$  also should be added in  $R$

$\Rightarrow$  Minimum number of elements to be added to  $R = 3 + 4 = 7$

**Q.23** The foci of a hyperbola are  $(\pm 2, 0)$  and its eccentricity is  $\frac{3}{2}$ . A tangent, perpendicular to the line  $2x + 3y = 6$ , is drawn at a point in the first quadrant on the hyperbola. If the intercepts made by the tangent on the  $x$ - and  $y$ -axes are  $a$  and  $b$  respectively, then  $|6a| + |5b|$  is equal to \_\_\_\_\_

**Ans.** [12]

**Sol.**  $\frac{x^2}{a^2} - \frac{y^2}{b^2} = 1, ae = 2, e = \frac{3}{2} \Rightarrow a = \frac{4}{3}$

$$b^2 = a^2 e^2 - a^2 = 4 - \frac{16}{9} = \frac{20}{9}$$

Equation of tangent,  $m = \frac{3}{2}$

$$y = \frac{3}{2}x - \sqrt{\frac{16}{9} \times \frac{9}{4} - \frac{20}{9}}$$

( $\because$  tangent is in 1<sup>st</sup> quadrant  $\Rightarrow C < 0$ )

$$\Rightarrow a = \frac{8}{9}, b = \frac{4}{3} \Rightarrow |6a| + |5b| = 12$$

**Q.24** If  $y = y(x)$  is the solution of the differential equation  $\frac{dy}{dx} + \frac{4x}{(x^2 - 1)}y = \frac{x + 2}{(x^2 - 1)}$ ,  $x > 1$  such that  $y(2) = \frac{2}{9}$

$\log_e(2 + \sqrt{3})$  and  $y(\sqrt{2}) = \alpha \log_e(\sqrt{\alpha} + \beta) + \beta - \sqrt{\gamma}$ ,  $\alpha, \beta, \gamma \in \mathbb{N}$ , then  $\alpha\beta\gamma$  is equal to \_\_\_\_\_.

**Ans.** [6]

**Sol.** IF =  $e^{\int \frac{4x}{x^2-1} dx} = (x^2 - 1)^2$

$$y(x^2 - 1)^2 = \int \frac{x + 2}{(x^2 - 1)^{1/2}} dx$$

$$y(x^2 - 1)^2 = \ln(|\sqrt{x^2 - 1} + x|) + \sqrt{x^2 - 1} + C$$

at  $x = 2$ ,

$$9 \cdot \frac{2}{9} \ln(2 + \sqrt{3}) = 2 \ln(2 + \sqrt{3}) + \sqrt{3} + C$$

$$C = -\sqrt{3}$$

at  $x = \sqrt{2}$

$$y(1) = 2 \ln(1 + \sqrt{2}) + 1 - \sqrt{3}$$

$$\beta = 1, \alpha = 2, \gamma = 3$$

**Q.25** Total numbers of 3-digit numbers that are divisible by 6 and can be formed by using the digits 1, 2, 3, 4, 5 with repetition, is \_\_\_\_\_

**Ans.** [16]

**Sol.** a b 2

$a + b$  can be 4, 7, 10

if  $a + b = 4$  then (a, b) can be (1, 3) OR (3, 1) OR (2, 2)

if  $a + b = 7$  then (a, b) can be (2, 5), (5, 2), (3, 4), (4, 3)

if  $a + b = 10$  then (a, b) can be (5, 5)

8 such cases when 2 is at unit's place similarly there exist 8 such cases when 4 is at unit's place.

Total = 16

**Q.26** For  $(-1, 1], \in x$  the number of solutions of the equation  $\sin^{-1} x = 2 \tan^{-1} x$  is equal to \_\_\_\_\_.

**Ans.** [2]

**Sol.**  $\sin(\sin^{-1} x) = \sin(2 \tan^{-1} x)$

$$x = \frac{2x}{1+x^2}; \quad x = 0, \pm 1 \quad \Rightarrow \quad x = 0 \text{ and } 1 \text{ are possible}$$

**Q.27** The mean and standard deviation of the marks of 10 students were found to be 50 and 12 respectively. Later, it was observed that two marks 20 and 25 were wrongly read as 45 and 50 respectively. Then the correct variance is \_\_\_\_\_.

**Ans.** [269]

**Sol.**  $\sum x_{i(\text{wrong})} = 500$

$$144 = \frac{\sum x_{i(\text{wrong})}^2}{10} - (50)^2$$

$$26440 = \sum x_{i(\text{wrong})}^2$$

$$\sum x_{i(\text{correct})} = 450$$

$$\Rightarrow \bar{x}_{i(\text{correct})} = 45$$

$$\sum x_{i(\text{correct})}^2 = 26440 - 3500 = 22940$$

$$\text{Variance} = \frac{22940}{10} - (45)^2 = 2294 - 2025 = 269$$

**Q.28** The remainder, when  $7^{103}$  is divided by 17, is \_\_\_\_\_

**Ans.** [12]

**Sol.**  $7^{103}$  divided by 17

$$7 \equiv 7 \pmod{17}$$

$$7^2 \equiv -2 \pmod{17}$$

$$7^6 \equiv -8 \pmod{17}$$

$$7^8 \equiv -1 \pmod{17}$$

$$7^{16} \equiv 1 \pmod{17}$$

$$7^{103} \equiv 12 \pmod{17}$$

$\therefore$  Remainder = 12

**Q.29** Let  $[\alpha]$  denote the greatest integer  $\leq \alpha$ . Then  $[\sqrt{1}] + [\sqrt{2}] + [\sqrt{3}] + \dots + [\sqrt{120}]$  is equal to \_\_\_\_\_.

**Ans.** [825]

**Sol.**  $[\sqrt{1}] + [\sqrt{2}] + [\sqrt{3}] + \dots + [\sqrt{120}]$

$$E = 1 + 1 + 1 + 2 + 2 + 2 + 2 + 2 + 2 + 3 + 3 + 3 + 3 + 3 + 3 + 3 + 3 + 4 + 4 + \dots$$

$$E = 3 \times 1 + 5 \times 2 + 7 \times 3 + \dots + 19 \times 9 + 10 \times 21$$

$$= \sum_{r=1}^{10} (2r+1)r = 2 \left[ \frac{10 \times 11 \times 21}{6} \right] + \frac{10 \times 11}{2} = 770 + 55 = 825$$

**Q.30** Let  $f(x) = \sum_{k=1}^{10} kx^k$ ,  $x \in \mathbb{R}$ . If  $2f(2) + f'(2) = 119(2)^n + 1$  then n is equal to \_\_\_\_\_.

**Ans.** [10]

**Sol.**  $f(x) = \sum_{k=1}^{10} kx^k$

$$S = x + 2x^2 + 3x^3 + \dots + 10x^{10}$$

$$S_x = x^2 + 2x^3 + \dots + 9x^{10} + 10x^{11}$$

$$S(1-x) = x + x^2 + x^3 + \dots + x^{10} - 10x^{11}$$

$$S(1-x) = \frac{x(1-x^{10})}{1-x} - 10x^{11}$$

$$S = \frac{x(1-x^{10})}{(1-x)^2} - \frac{10x^{11}}{(1-x)} = f(x)$$

$$f(2) = 2(1-2^{10}) + 10 \cdot 2^{11}$$

$$= 2 + 18 \cdot 2^{10}$$

$$f' = \frac{-10x^{11}}{(1-x)^2} - \frac{110x^{10}}{1-x} - \frac{10x^{10}}{(1-x)^2} + \frac{2x(1-x^{10})}{(1-x)^3} + \frac{1-x^{10}}{(1-x)}$$

$$2f(2) + f'(2) = 119(2)^{10} + 1$$

$\therefore n = 10$

## PHYSICS

**Section-A:** Multiple Choice Questions: This section contains 20 multiple choice questions. Each question has 4 choices (1), (2), (3) and (4), out of which **ONLY ONE** is correct.

**Q.23** Given below are two statements:

**Statement I :** Out of microwaves, infrared rays and ultraviolet rays, ultraviolet rays are the most effective for the emission of electrons from a metallic surface.

**Statement II :** Above the threshold frequency, the maximum kinetic energy of photoelectrons is inversely proportional to the frequency of the incident light.

In the light of above statements, choose the correct answer from the options given below

- (1) Statement I is false but Statement II is true  
(2) Statement I is true but Statement II is false  
(3) Both Statement I and Statement II are true  
(4) Both Statement I and Statement II are false

Ans. [2]

Sol. Since UV would be having highest frequency,  
⇒ Most effective for electron emission.

Also,  $K_{\max} = hf - \phi$

⇒ Statement II is wrong

Q.32 The distance travelled by an object in time  $t$  is given by  $s = (2.5)t^2$ . The instantaneous speed of the object at  $t = 5$  s will be :

- (1)  $25 \text{ ms}^{-1}$  (2)  $5 \text{ ms}^{-1}$  (3)  $62.5 \text{ ms}^{-1}$  (4)  $12.5 \text{ ms}^{-1}$

Ans. [1]

Sol.  $s = 2.5t^2$

⇒ Speed =  $5t$

⇒ At  $t = 5$  s, speed =  $25 \text{ m/s}$

Q.33 In a Young's double slit experiment, the ratio of amplitude of light coming from slits is  $2 : 1$ . The ratio of the maximum to minimum intensity in the interference pattern is :

- (1)  $9 : 4$  (2)  $25 : 9$  (3)  $2 : 1$  (4)  $9 : 1$

Ans. [4]

Sol. 
$$\frac{I_{\max}}{I_{\min}} = \frac{(\sqrt{I_1} + \sqrt{I_2})^2}{(\sqrt{I_1} - \sqrt{I_2})^2} = \left(\frac{A_1 + A_2}{A_1 - A_2}\right)^2 = \left(\frac{2+1}{2-1}\right)^2 = 9$$

Q.34 A  $10 \mu\text{C}$  charge is divided into two parts and placed at  $1 \text{ cm}$  distance so that the repulsive force between them is maximum. The charges of the two parts are:

- (1)  $7 \mu\text{C}, 3 \mu\text{C}$  (2)  $8 \mu\text{C}, 2 \mu\text{C}$  (3)  $5 \mu\text{C}, 5 \mu\text{C}$  (4)  $9 \mu\text{C}, 1 \mu\text{C}$

Ans. [3]

Sol. We know that for  $\frac{Q}{2}, \frac{Q}{2}$  force would be maximum.

Q.35 A passenger sitting in a train A moving at  $90 \text{ km/h}$  observes another train B moving in the opposite direction for  $8 \text{ s}$ . If the velocity of the train B is  $54 \text{ km/h}$ , then length of train B is:

- (1)  $120 \text{ m}$  (2)  $320 \text{ m}$  (3)  $80 \text{ m}$  (4)  $200 \text{ m}$

Ans. [2]

Sol. Relative velocity =  $144 \text{ km/h}$

=  $40 \text{ m/s}$

⇒ Length =  $40 \text{ m/s} \times 8 \text{ s}$

=  $320 \text{ m}$

Q.36 The initial pressure and volume of an ideal gas are  $P_0$  and  $V_0$ . The final pressure of the gas when the gas is suddenly compressed to volume  $\frac{V_0}{4}$  will be:

(Given  $\gamma$  = ratio of specific heats at constant pressure and at constant volume)

- (1)  $P_0(4)^\gamma$  (2)  $4P_0$  (3)  $P_0$  (4)  $P_0(4)^{\frac{1}{\gamma}}$

Ans. [1]

Sol.  $PV^\gamma = \text{constant}$

$$P_0 V_0^\gamma = P \cdot \left(\frac{V_0}{4}\right)^\gamma \Rightarrow P = 4^\gamma \cdot P_0$$

- Q.37** A vehicle of mass 200 kg is moving along a leveled curved road of radius 70 m with angular velocity of 0.2 rad/s. The centripetal force acting on the vehicle is:  
 (1) 560 N (2) 2800 N (3) 2240 N (4) 14 N

**Ans.** [1]

**Sol.**  $F = MR\omega^2$   
 $= 200 \times 70 \times 0.2^2 \text{ N}$   
 $= 560 \text{ N}$

- Q.38** In the network shown below, the charge accumulated in the capacitor in steady state will be:

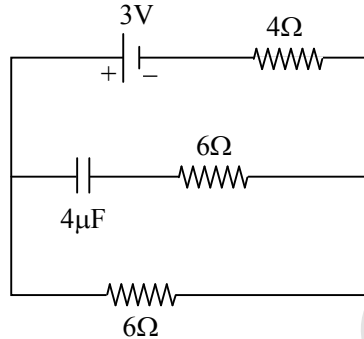

- (1) 10.3  $\mu\text{C}$  (2) 4.8  $\mu\text{C}$  (3) 12  $\mu\text{C}$  (4) 7.2  $\mu\text{C}$

**Ans.** [4]

**Sol.** In steady state, capacitor behaves as open circuit.

$$\Rightarrow \Delta V_C = i \times 6 \Omega$$

$$= \frac{3}{10} \times 6 \text{ V}$$

$$= 1.8 \text{ V}$$

$$\Rightarrow Q = CV = 7.2 \mu\text{C}$$

- Q.39** Given below are two statements:

**Statement I :** An AC circuit undergoes electrical resonance if it contains either a capacitor or an inductor.

**Statement II:** An AC circuit containing a pure capacitor or a pure inductor consumes high power due to its non-zero power factor.

In the light of above statements, choose the correct answer from the options given below:

- (1) Statement I is false but statement II is true (2) Statement I is true but statement II is false  
 (3) Both Statement I and Statement II are false (4) Both Statement I and Statement II are true

**Ans.** [3]

**Sol.** For resonance,  $X_L = X_C$

$\Rightarrow$  Both inductor and capacitor would be required.

Also, for pure capacitor or pure inductor power factor = 0

$\Rightarrow$  Both statements are incorrect

- Q.40** A particle executes SHM of amplitude A. The distance from the mean position when its kinetic energy becomes equal to its potential energy is:

- (1)  $\frac{1}{\sqrt{2}} \text{ A}$  (2) 2A (3)  $\sqrt{2} \text{ A}$  (4)  $\frac{1}{2} \text{ A}$

**Ans.** [1]

**Sol.**  $\frac{1}{2} m\omega^2 (A^2 - x^2) = \frac{1}{2} m\omega^2 x^2 = x = \frac{A}{\sqrt{2}}$

**Q.41** In the equation  $\left[X + \frac{a}{Y^2}\right] [Y - b] = RT$ , X is pressure, Y is volume, R is universal gas constant T is temperature. The physical quantity equivalent to the ratio  $\frac{a}{b}$  is:

- (1) Pressure gradient (2) Energy  
(3) Impulse (4) Coefficient of viscosity

**Ans.** [2]

**Sol.**  $a \equiv PV^2$

$b \equiv V$

$\Rightarrow \frac{a}{b} \equiv PV \equiv \text{Energy}$

**Q.42** To radiate EM signal of wavelength  $\lambda$  with high efficiency, The antennas should have a minimum size equal to:

- (1)  $2\lambda$  (2)  $\frac{\lambda}{2}$  (3)  $\frac{\lambda}{4}$  (4)  $\lambda$

**Ans.** [3]

**Sol.** Length of antenna =  $\frac{\lambda}{4}$

**Q.43** Given below are two statements: one is labelled as **Assertion A** and the other is labelled as **Reason R**  
**Assertion A** : A spherical body of radius  $(5 \pm 0.1)$  mm having a particular density is falling through a liquid of constant density. The percentage error in the calculation of its terminal velocity is 4%.

**Reason R** : The terminal velocity of the spherical body falling through the liquid is inversely proportional to its radius.

In the light of the above statements, choose the correct answer from the options given below

- (1) Both **A** and **R** are true and **R** is the correct explanation of **A**  
(2) Both **A** and **R** are true but **R** is **NOT** the correct explanation of **A**  
(3) **A** is true but **R** is false  
(4) **A** is false but **R** is true

**Ans.** [3]

**Sol.**  $V_T = \frac{2}{9} r^2 g \frac{(\rho - \rho')}{\eta} \propto r^2$

$\Rightarrow \frac{dV_T}{V_T} = 2 \frac{dr}{r} = 2 \times \frac{0.1}{5} = 4\%$

**Q.44** The output from a NAND gate having inputs A and B given below will be,

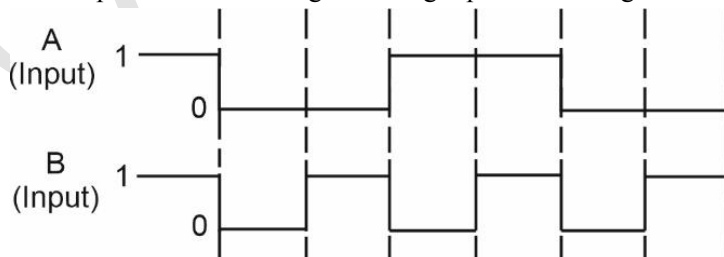

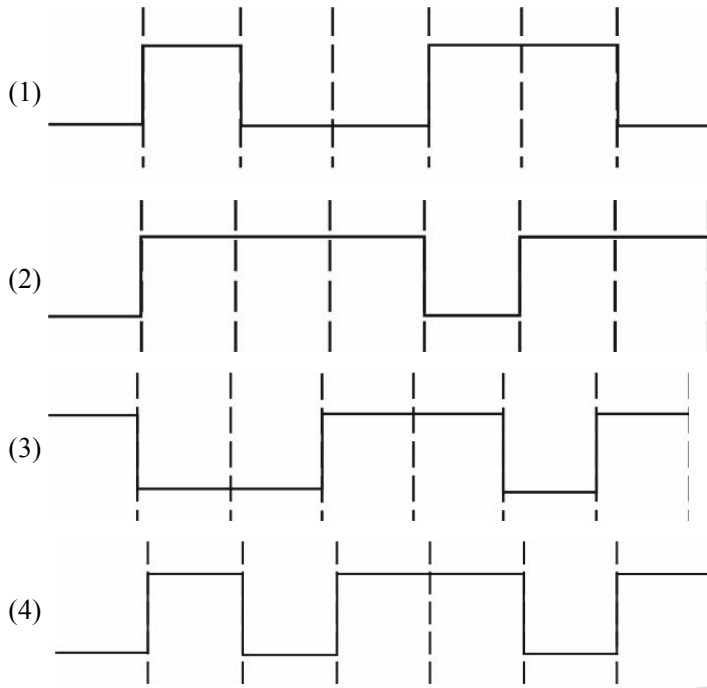

**Ans.** [2]

**Sol.**  $Y = (AB)'$

$\Rightarrow Y$  would be zero only when both A and B are 1.

$\Rightarrow$  option 2.

**Q.45** The mean free path of molecules of a certain gas at STP is  $1500d$ , where  $d$  is the diameter of the gas molecules. While maintaining the standard pressure, the mean free path of the molecules at  $373\text{ K}$  is approximately:

(1)  $750d$

(2)  $1098d$

(3)  $2049d$

(4)  $1500d$

**Ans.** [3]

**Sol.** Mean free path =  $\frac{1}{\sqrt{2}\pi nd^2}$

$$\Rightarrow \frac{1500d}{\lambda'} = \frac{273}{373}$$

$$\Rightarrow \lambda' = 2049.45d$$

**Q.46** Two planets A and B of radii  $R$  and  $1.5R$  have densities  $\rho$  and  $\rho/2$  respectively. The ratio of acceleration due to gravity at the surface of B to A is:

(1)  $2 : 3$

(2)  $2 : 1$

(3)  $3 : 4$

(4)  $4 : 3$

**Ans.** [3]

**Sol.**  $g = \frac{GM}{R^2} \propto \rho \cdot R$

$$\Rightarrow \frac{g_B}{g_A} = \frac{1}{2} \times 1.5 = 0.75$$

**Q.47** In an electromagnetic wave, at an instant and at a particular position, the electric field is along the negative  $z$ -axis and magnetic field is along the positive  $x$ -axis. Then the direction of propagation of electromagnetic wave is:

(1) positive  $z$ -axis

(2) positive  $y$ -axis

(3) at  $45^\circ$  angle from positive  $y$ -axis

(4) negative  $y$ -axis



Ans. [4]

Sol.  $\hat{C} = \hat{E} \times \hat{B}$   
 $\Rightarrow \hat{C}$  is along  $-y$  axis

**Q.48** An electron is moving along the positive x-axis. If uniform magnetic field is applied parallel to the negative z-axis, then

- A. The electron will experience magnetic force along positive y-axis
- B. The electron will experience magnetic force along negative y-axis
- C. The electron will not experience any force in magnetic field
- D. The electron will continue to move along the positive x-axis
- E. The electron will move along circular path in magnetic field

Choose the correct answer from the option given below:

- (1) A and E only                      (2) C and D only                      (3) B and E only                      (4) B and D only

Ans. [3]

Sol.  $\vec{F} = q\vec{v} \times \vec{B}$   
 $= -3\vec{v} \times \vec{B}$   
 $\Rightarrow \vec{F}$  along  $-y$  axis  
Also, motion would be circular.

**Q.49** Given below are two statements: one is labelled as **Assertion A** and the other is labelled as **Reason R**  
**Assertion A** : The binding energy per nucleon is practically independent of the atomic number for nuclei of mass number in the range 30 to 170.

**Reason R** : Nuclear force is short ranged.

In the light of the above statements, choose the **correct** answer from the options given below

- (1) **A** is false but **R** is true
- (2) Both **A** and **R** are true and **R** is the correct explanation of **A**
- (3) Both **A** and **R** are true but **R** is NOT the correct explanation of **A**
- (4) **A** is true but **R** is false

Ans. [2]

Sol. Binding energy per nucleon is almost constant in the mass number range 30 – 170. This is because nuclear force is a short-range force.

**Q.50** Given below are two statements:

**Statement I** : For a planet, if the ratio of mass of the planet to its radius increase, the escape velocity from the planet also increase.

**Statement II** : Escape velocity is independent of the radius of the planet.

In the light of above statements, choose the **most appropriate** answer from the options given below

- (1) Statement I is incorrect but Statement II is correct
- (2) Statement I is correct but statement II is incorrect
- (3) Both Statement I and Statement II are incorrect
- (4) Both Statement I and Statement II are correct

Ans. [2]

Sol.  $v_{\text{esc}} = \frac{2GM}{R}$   
 $\Rightarrow$  Statement I is correct while statement II is wrong.

---

**Section-B: Numerical Value Type Questions:** This section contains 10 questions. In Section B, attempt any five questions out of 10. The answer to each question is a **NUMERICAL VALUE**. For each question, enter the correct numerical value (in decimal notation, truncated/rounded-off to the second decimal place; e.g., 06.25, 07.00, -00.33, -00.30, 30.27, -27.30) using the mouse and the on-screen virtual numeric keypad in the place designated to enter the answer.

---

**Q.51** Two plates A and B have thermal conductivities  $84 \text{ Wm}^{-1}\text{K}^{-1}$  and  $126 \text{ Wm}^{-1}\text{K}^{-1}$  respectively. They have same surface area and same thickness. They are placed in contact along their surfaces. If the temperatures of the outer surfaces of A and B are kept at  $100^\circ\text{C}$  and  $0^\circ\text{C}$  respectively, then the temperature of the surface of contact in steady state is \_\_\_\_\_  $^\circ\text{C}$ .

**Ans.** [40]

**Sol.** 
$$\frac{84 \cdot A \cdot (100 - T)}{L} = \frac{126 \cdot A \cdot (T - 0)}{L}$$

$$\Rightarrow 200 - 2T = 3T$$

$$\Rightarrow T = 40^\circ\text{C}$$

**Q.52** An atom absorbs a photon of wavelength 500 nm and emits another photon of wavelength 600 nm. The net energy absorbed by the atom in this process is  $n \times 10^{-4}$  eV. The value of n is \_\_\_\_\_.  
[Assume the atom to be stationary during the absorption and emission process] (Take  $h = 6.6 \times 10^{-34}$  Js and  $c = 3 \times 10^8$  m/s).

**Ans.** [4125]

**Sol.** 
$$\Delta E = \frac{hc}{\lambda_1} - \frac{hc}{\lambda_2}$$

$$= \frac{6.6 \times 10^{-34} \times 3 \times 10^8 \times 100}{500 \times 600 \times 10^{-9}}$$

$$= \frac{6.6 \times 3}{30} \times 10^{-19} \text{ V}$$

$$= \frac{6.6 \times 3}{30 \times 1.6} \text{ eV}$$

$$= \frac{6.6 \times 3 \times 10^4}{30 \times 16} \times 10^{-4} \text{ eV}$$

$$= 4125 \times 10^{-4} \text{ eV}$$

**Q.53** A bi convex lens of focal length 10 cm is cut in two identical parts along a plane perpendicular to the principal axis. The power of each lens after cut is \_\_\_\_\_ D.

**Ans.** [5]

**Sol.** 
$$\frac{1}{f} = (\mu - 1) \left( \frac{2}{R} \right)$$

$$\frac{1}{f'} = (\mu - 1) \left( \frac{1}{R} \right)$$

$$\Rightarrow \frac{P'}{P} = \frac{1}{2}$$

$$\Rightarrow P' = \frac{P}{2} = 5D$$

**Q.54** Three point charges  $q$ ,  $-2q$  and  $2q$  are placed on xaxis at a distance  $x = 0$ ,  $x = \frac{3}{4}R$  and  $x = R$  respectively from origin as shown. If  $q = 2 \times 10^{-6}$  C and  $R = 2$  cm, the magnitude of net force experienced by the charge  $-2q$  is \_\_\_\_\_ N.

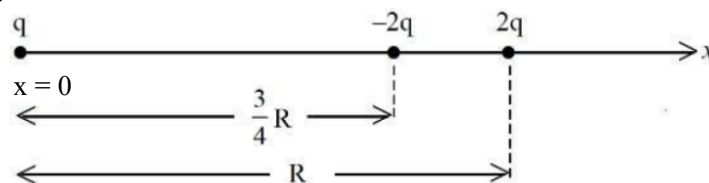

Ans. [5440]

Sol. 
$$\frac{1}{4\pi\epsilon_0} \frac{4q^2}{\left(\frac{R}{4}\right)^2} - \frac{1}{4\pi\epsilon_0} \frac{2q^2}{\left(\frac{3R}{4}\right)^2}$$

$$= 9 \times 10^9 \times \frac{16q^2}{R^2} \left[4 - \frac{2}{9}\right]$$

$$= \frac{9 \times 10^9 \times 16 \times 4 \times 10^{-12}}{4} \times \frac{34}{9} \text{ N} = 5440 \text{ N}$$

**Q.55** A straight wire AB of mass 40 g and length 50 cm is suspended by a pair of flexible leads in uniform magnetic field of magnitude 0.40 T as shown in the figure. The magnitude of the current required in the wire to remove the tension in the supporting leads is \_\_\_\_\_ A. (Take  $g = 10 \text{ ms}^{-2}$ ).

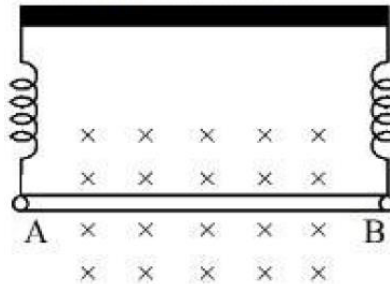

Ans. [2]

Sol. On current carrying wires

$$ILB = Mg$$

$$\Rightarrow I = \frac{\frac{40}{1000} \times 10}{0.5 \times 0.4} = 2 \text{ A}$$

**Q.56** In an experiment with sonometer when a mass of 180 g is attached to the string, it vibrates with fundamental frequency of 30 Hz. When a mass  $m$  is attached, the string vibrates with fundamental frequency of 50 Hz. The value of  $m$  is \_\_\_\_\_ g.

Ans. [500]

Sol. 
$$f = \frac{v}{2L} = \frac{1}{2L} \sqrt{\frac{T}{\mu}}$$

$$\Rightarrow \frac{30}{50} = \sqrt{\frac{180}{m}}$$

$$\Rightarrow m = 180 \times \frac{25}{9} = 500 \text{ grams}$$

**Q.57** A light rope is wound around a hollow cylinder of mass 5 kg and radius 70 cm. The rope is pulled with a force of 52.5 N. The angular acceleration of the cylinder will be \_\_\_\_\_  $\text{rad s}^{-2}$ .

Ans. [15]

Sol.  $\tau = I\alpha$

$$\Rightarrow \alpha = \frac{52.5 \times \frac{70}{100}}{5 \times \left(\frac{70}{100}\right)^2} = 10.5 \times \frac{10}{7} = 15 \text{ rad/s}^2$$

**Q.58** A car accelerates from rest of  $u$  m/s. The energy spent in this process is  $E$  J. The energy required to accelerate the car from  $u$  m/s is to  $2u$  m/s is  $nE$  J. The value of  $n$  is \_\_\_\_\_.

**Ans.** [3]

**Sol.**  $E = \frac{1}{2} mv^2 \quad \dots(1)$

$$nE = \frac{1}{2} m \{(2v)^2 - v^2\} \quad \dots(2)$$

$$\Rightarrow n = 3$$

**Q.59** An insulated copper wire of 100 turns is wrapped around a wooden cylindrical core of the cross-sectional area  $24 \text{ cm}^2$ . The two ends of the wire are connected to a resistor. The total resistance in the circuit is  $12\Omega$ . If an externally applied uniform magnetic field in the core along its axis changes from  $1.5 \text{ T}$  in one direction to  $1.5 \text{ T}$  in the opposite direction, the charge flowing through a point in the circuit during the change of magnetic field will be \_\_\_\_\_ mC.

**Ans.** [60]

**Sol.**  $\varepsilon = \frac{-d\theta}{dt} = iR$

$$\Rightarrow \int idt = \frac{-\Delta\phi}{R}$$

$$\Rightarrow -\frac{1}{R} [2 \times 1.5 \times 24 \times 10^{-4}] \times 100 \text{ C}$$

$$\Rightarrow \text{Charge} = \frac{0.72}{12} \text{ C} \\ = 60 \text{ mC}$$

**Q.60** In the circuit shown, the energy stored in the capacitor is  $n \mu\text{J}$ . The value of  $n$  is \_\_\_\_\_.

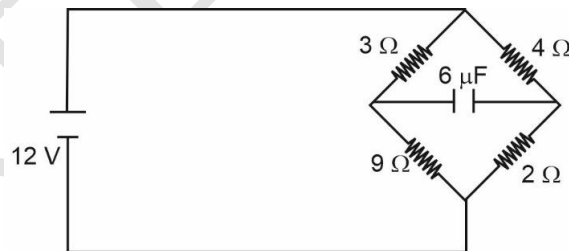

**Ans.** [75]

**Sol.** Capacitor would behave as open circuit.

$$\Delta V_C = \left( \frac{4}{6} \times 12 - \frac{3}{12} \times 12 \right) \text{ volts}$$

$$= (8 - 3) \text{ V} = 5\text{V}$$

$$\Rightarrow U = \frac{1}{2} C(5)^2$$

$$= 75 \mu\text{J}$$

**CHEMISTRY**

**Section-A:** This section contains 20 multiple choice questions. Each question has 4 choices(1), (2), (3) and (4), out of which **ONLY ONE** is correct..

**Q.61** Match List-I with List-II.

1-Bromopropane is reacted with reagents in List-I to give product in List-II

List-I Reagent		List-II Product	
A.	KOH (alc)	I.	Nitrile
B.	KCN (alc)	II.	Ester
C.	AgNO <sub>2</sub>	III.	Alkene
D.	H <sub>3</sub> CCOOAg	IV.	Nitroalkane

Choose the correct answer from the options given below

(1) A-III, B-I, C-IV, D-II

(2) A-I, B-II, C-III, D-IV

(3) A-I, B-III, C-IV, D-II

(4) A-IV, B-III, C-II, D-I

**Ans.** [1]

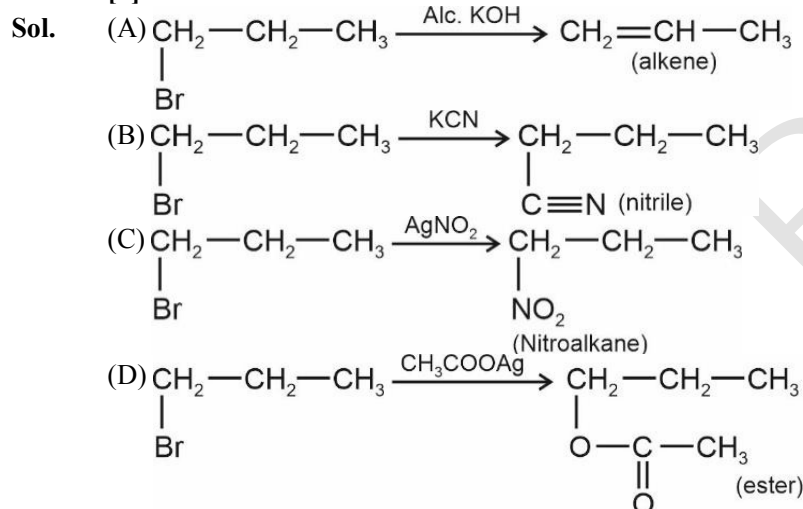

**Q.62** In the wet tests for detection of various cations by precipitation, Ba<sup>2+</sup> cations are detected by obtaining precipitate of

(1) Ba(ox) : Barium oxalate

(2) BaCO<sub>3</sub>

(3) Ba(OAc)<sub>2</sub>

(4) BaSO<sub>4</sub>

**Ans.** [2]

**Sol.** Ba<sup>2+</sup> belongs to V<sup>th</sup> Group and hence they are precipitated with CO<sub>3</sub><sup>2-</sup> to give ppt of BaCO<sub>3</sub>.

**Q.63** Match List-I with List-II.

List-I		List-II	
A.	Weak intermolecular forces of attraction	I.	Hexamethylenediamine + adipic acid
B.	Hydrogen bonding	II.	AlEt <sub>3</sub> + TiCl <sub>4</sub>
C.	Heavily branched polymer	III.	2-chloro-1, 3-butadiene
D.	High density polymer	IV.	Phenol + formaldehyde

Choose the correct answer from the options given below :

(1) A-IV, B-II, C-III, D-I

(2) A-IV, B-I, C-III, D-II

(3) A-II, B-IV, C-I, D-III

(4) A-III, B-I, C-IV, D-II

**Ans.** [4]

- Sol.** (A) Weak Intermolecular Forces are present in polymer of 2-chloro, 1, 3-butadiene  
 (B) Hydrogen Bonding is present in NYLON-66 which is a polymer of Hexamethylenediamine and adipic acid  
 (C) Heavily branched polymer is Bakelite which is polymer of phenol and formaldehyde  
 (D) High density polymer preparation requires  $Al(Et)_3$  and  $TiCl_4$  as a catalyst (Ziegler Natta Catalyst)

- Q.64** The covalency and oxidation state respectively of boron in  $[BF_4]^-$ , are :  
 (1) 3 and 5 (2) 3 and 4 (3) 4 and 4 (4) 4 and 3

**Ans.** [4]

**Sol.**  $[BF_4]^-$

Covalency = No. of Bonds = 4

Oxidation state = +3 for Boron

- Q.65** Identify the correct order of standard enthalpy of formation of sodium halides.  
 (1)  $NaI < NaBr < NaF < NaCl$  (2)  $NaI < NaBr < NaCl < NaF$   
 (3)  $NaF < NaCl < NaBr < NaI$  (4)  $NaCl < NaF < NaBr < NaI$

**Ans.** [2]

**Sol.** Lattice energy  $\propto \frac{1}{(r_+ + r_-)}$

Size  $\uparrow$  Enthalpy of formation  $\downarrow$

Order :

$NaF > NaCl > NaBr > NaI$

- Q.66** What happens when methane undergoes combustion in systems A and B respectively?

Adiabatic system	Diathermic container
System A	System B

	System A	System B
(1)	Temperature rises	Temperature remains same
(2)	Temperature remains same	Temperature rises
(3)	Temperature falls	Temperature remains same
(4)	Temperature falls	Temperature rises

**Ans.** [1]

**Sol.** For adiabatic system, heat will not escape and temperature of system will rise.

For diathermic container, heat will escape the container and hence temperature of container will remain same.

- Q.67** Which of the following complexes will exhibit maximum attraction to an applied magnetic field?  
 (1)  $[Ni(H_2O)_6]^{2+}$  (2)  $[Co(en)_3]^{3+}$  (3)  $[Zn(H_2O)_6]^{2+}$  (4)  $[Co(H_2O)_6]^{2+}$

**Ans.** [4]

**Sol.** Complex having maximum number of unpaired electrons will exhibit maximum attraction to applied magnetic field.

$[Ni(H_2O)_6]^{2+} = 2$  unpaired electrons

$[Co(en)_3]^{3+} = 0$  unpaired electrons

$[Zn(H_2O)_6]^{2+} = 0$  unpaired electrons

$[Co(H_2O)_6]^{2+} = 3$  unpaired electrons

- Q.68** Given below are two statements, one is labelled as **Assertion A** and the other is labelled as **Reason R**.  
**Assertion A** : The diameter of colloidal particles in solution should not be much smaller than wavelength of light to show Tyndall effect.  
**Reason R** : The light scatters in all directions when the size of particles is large enough.

In the light of the above statements, choose the correct answer from the options given below :

- (1) Both A and R are correct but R is NOT the correct explanation of A
- (2) A is true but R is false
- (3) A is false but R is true
- (4) Both A and R are correct and R is the correct explanation of A

**Ans.** [4]

**Sol.** Conditions for Tyndall effect:

- (i) Diameter of colloidal particles in solution is not much smaller than wavelength of the light used.
  - (ii) The refractive indices of the dispersed phase and dispersion medium differ greatly in magnitude.
- If size of particles is large enough than light scatters in all directions.

**Q.69** Given below are two statements, one is labelled as **Assertion A** and the other is labelled as **Reason R**.  
**Assertion A** : Isotopes of hydrogen have almost same chemical properties, but difference in their rates of reactions.

**Reason R**: Isotopes of hydrogen have different enthalpy of bond dissociation.

In the light of the above statements, choose the most appropriate answer from the options given below:

- (1) Both A and R are correct but R is NOT the correct explanation of A
- (2) Both A and R are correct and R is the correct explanation of A
- (3) A is not correct but R is correct
- (4) A is correct but R is not correct

**Ans.** [2]

**Sol.** Isotopes of hydrogen have almost same chemical properties, but rate will be different due to difference in bond dissociation enthalpy.

**Q.70** The major product for the following reaction is :

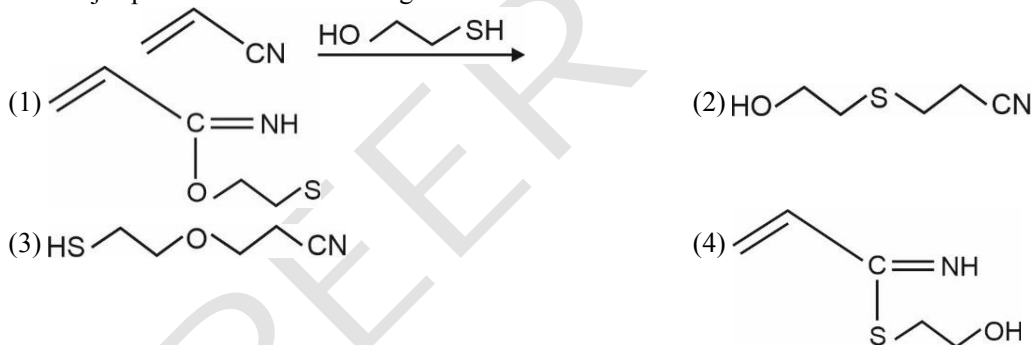

**Ans.** [2]

**Sol.** Nucleophilicity: SH > OH  
 Stable carbocation will be that which is away from CN group.

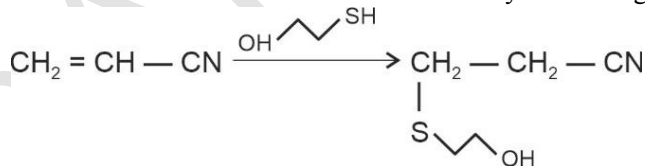

**Q.71** Compound A from the following reaction sequence is :

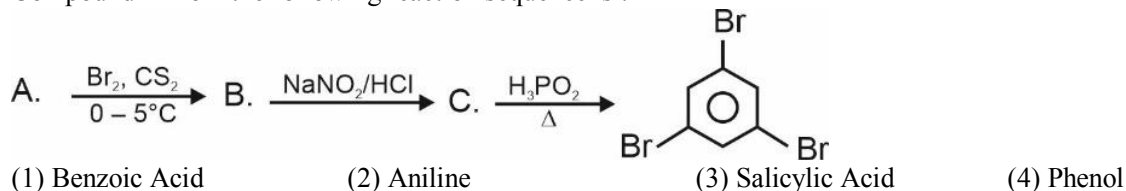

**Ans.** [2]

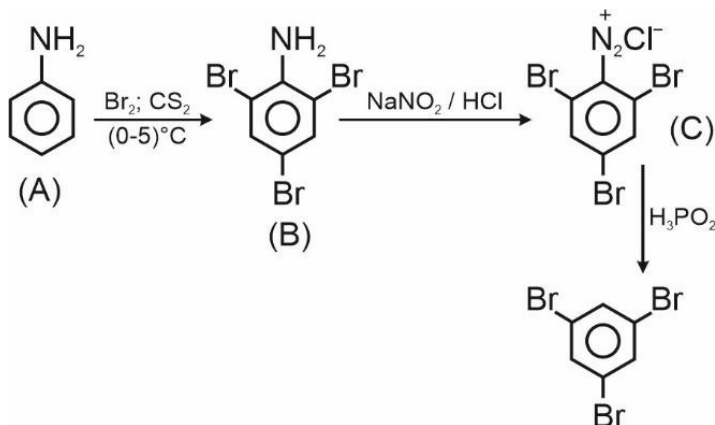
**Sol.**

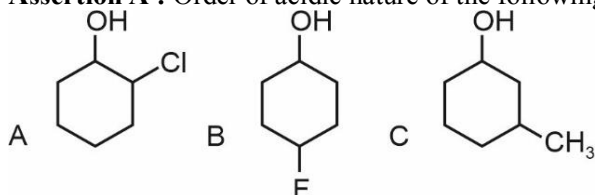
**Q.72** Given below are two statements, one is labelled as **Assertion A** and the other is labelled as **Reason R**.

**Assertion A :** Order of acidic nature of the following compounds is  $A > B > C$ .

**Reason R:** Fluoro is a stronger electron withdrawing group than Chloro group.

In the light of the above statements, choose the correct answer from the options given below :

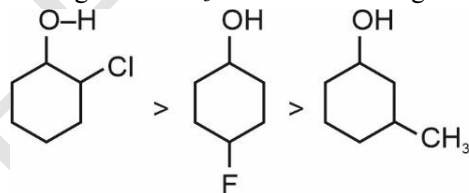
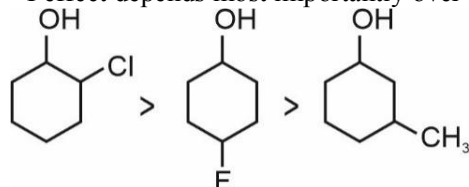
- (1) A is false but R is true
- (2) Both A and R are correct and R is the correct explanation of A
- (3) A is true but R is false
- (4) Both A and R are correct but R is NOT the correct explanation of A

**Ans.** [4]

**Sol.** The F & Cl are electron withdrawing while  $\text{CH}_3$  is electron loosing hence acidic strength will be

 On further differentiation the  $-I$  effect depends most importantly over distance hence.

 The F has higher  $-I$  effect as compared to Cl hence reason is correct statement but the  $-I$  effect depends more

 on distance as compared to power Oc1ccccc1Cl hence is stronger acid than Oc1ccccc1F
**Q.73** The correct group of halide ions which can be oxidised by oxygen in acidic medium is :

- (1)  $\text{Br}^-$  and  $\text{I}^-$  only
- (2)  $\text{Br}^-$  only
- (3)  $\text{I}^-$  only
- (4)  $\text{Cl}^-$ ,  $\text{Br}^-$  and  $\text{I}^-$  only



**Ans.** [3]

**Sol.** Fluorine oxidises water to oxygen whereas chlorine & bromine react with water to form corresponding HX & HOX acids. The reaction of I<sub>2</sub> with water is nonspontaneous. In fact I<sup>-</sup> can be oxidised by oxygen in acidic medium.

It is why the I<sup>-</sup> in nature is not present in that much amount as other halides are present in nature.

**Q.74** Given below are two statements :

**Statement I :** SO<sub>2</sub> and H<sub>2</sub>O both possess V-shaped structure.

**Statement II :** The bond angle of SO<sub>2</sub> is less than that of H<sub>2</sub>O.

In the light of the above statements, choose the most appropriate answer from the options given below:

- (1) Both Statement I and Statement II are incorrect
- (2) Both Statement I and Statement II are correct
- (3) Statement I is incorrect but Statement II is correct
- (4) Statement I is correct but Statement II is incorrect

**Ans.** [4]

**Sol.**

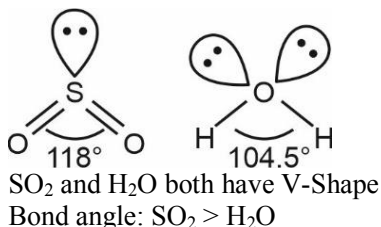

**Q.75** Better method for preparation of BeF<sub>2</sub>, among the following is

- (1)  $\text{BeO} + \text{C} + \text{F}_2 \xrightarrow{\Delta} \text{BeF}_2$
- (2)  $(\text{NH}_4)_2\text{BeF}_4 \xrightarrow{\Delta} \text{BeF}_2$
- (3)  $\text{Be} + \text{F}_2 \xrightarrow{\Delta} \text{BeF}_2$
- (4)  $\text{BeH}_2 + \text{F}_2 \xrightarrow{\Delta} \text{BeF}_2$

**Ans.** [2]

**Sol.**  $(\text{NH}_4)_2\text{BeF}_4 \rightarrow 2\text{NH}_4\text{F} + \text{BeF}_2$

**Q.76** Given below are two statements :

**Statement I :** Tropolone is an aromatic compound and has 8 π electrons.

**Statement II :** π electrons of >C = O group in tropolone is involved in aromaticity.

In the light of the above statements choose the correct answer from the options given below:

- (1) Statement I is true but Statement II is false
- (2) Statement I is false but Statement II is true
- (3) Both Statement I and Statement II are false
- (4) Both Statement I and Statement II are true

**Ans.** [1]

**Sol.**

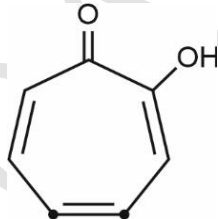

Tropolone has 8π electrons

π-electrons of group does not get involved in aromaticity.

**Q.77** The naturally occurring amino acid that contains only one basic functional group in its chemical structure is :

- (1) asparagine
- (2) histidine
- (3) arginine
- (4) lysine

Ans. [1]

Sol. Asparagine have only one Basic Functional Group Structure of Asparagine:

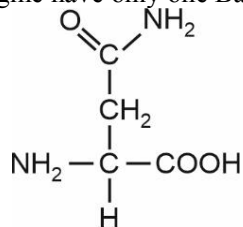

Q.78 Given below are two statements related to Ellingham diagram :

**Statement I :** Ellingham diagrams can be constructed for formation of oxides, sulfides and halides of metals.

**Statement II :** It consists of plots of  $\Delta_f H^\circ$  vs T for formation of oxides of elements.

In the light of the above statements, choose the most appropriate answer from the options given below :

- (1) Both Statement I and Statement II are correct
- (2) Both Statement I and Statement II are incorrect
- (3) Statement I is correct but Statement II is incorrect
- (4) Statement I is incorrect but Statement II is correct

Ans. [3]

Sol. Ellingham diagram have plot of of  $\Delta G_f^\circ$  vs. temperature

Q.79 Which of the following are the Green house gases?

- A. Water vapour
- B. Ozone
- C.  $\text{I}_2$
- D. Molecular hydrogen

Choose the most appropriate answer from the options given below :

- (1) A and D only                      (2) B and C only                      (3) A and B only                      (4) C and D only

Ans. [3]

Sol.  $\text{I}_2$  and  $\text{H}_2$  are not green house gases.

Q.80 The total number of stereoisomers for the complex  $[\text{Cr}(\text{ox})_2\text{ClBr}]^{3-}$  (where ox = oxalate) is :

- (1) 3                                      (2) 2                                      (3) 4                                      (4) 1

Ans. [1]

Sol. Cis - 2

trans - 1

Total 3 stereoisomers.

**Section-B: Numerical Value Type Questions:** This section contains 10 questions. In Section B, attempt any five questions out of 10. The answer to each question is a **NUMERICAL VALUE**. For each question, enter the correct numerical value (in decimal notation, truncated/rounded-off to the second decimal place; e.g., 06.25, 07.00, -00.33, -00.30, 30.27, -27.30) using the mouse and the on-screen virtual numeric keypad in the place designated to enter the answer..

Q.81 1g of a carbonate ( $\text{M}_2\text{CO}_3$ ) on treatment with excess HCl produces 0.01 mol of  $\text{CO}_2$ . The molar mass of  $\text{M}_2\text{CO}_3$  is \_\_\_\_\_  $\text{g mol}^{-1}$ . (Nearest integer)

Ans. [100]

Sol.  $\text{M}_2\text{CO}_3 + 2\text{HCl} \rightarrow \text{M}_2\text{Cl}_2 + \text{H}_2\text{O} + \text{CO}_2$

0.01 mole                                      0.01 mole

$$\Rightarrow \frac{1}{\text{MW}} = 0.01$$

$$\text{MW} = 100 \left( \frac{\text{gm}}{\text{mole}} \right)$$

- Q.82** 20 mL of 0.1 M NaOH is added to 50 mL of 0.1 M acetic acid solution. The pH of the resulting solution is \_\_\_\_\_  $\times 10^{-2}$ . (Nearest integer)  
 Given :  $pK_a(\text{CH}_3\text{COOH}) = 4.76$   
 $\log 2 = 0.30$   
 $\log 3 = 0.48$

**Ans.** [458]

**Sol.**

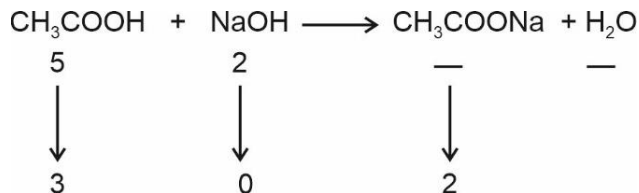

$$\text{pH} = \text{p}K_a + \log \left( \frac{2}{3} \right)$$

$$\begin{aligned} \text{pH} &= 4.76 + 0.30 - 0.48 \\ &= 4.76 - .18 \\ &= 4.58 \end{aligned}$$

- Q.83** If the formula of Borax is  $\text{Na}_2\text{B}_4\text{O}_x(\text{OH})_y \cdot z\text{H}_2\text{O}$ , then  $x + y + z =$  \_\_\_\_\_

**Ans.** [17]

**Sol.** Borax is  $\text{Na}_2[\text{B}_4\text{O}_5(\text{OH})_4] \cdot 8\text{H}_2\text{O}$

$$\underline{x = 5}$$

$$\underline{y = 4}$$

$$\underline{z = 8}$$

$$(x + y + z) = 5 + 4 + 8 = 17$$

- Q.84** At 298 K, the standard reduction potential for  $\text{Cu}^{2+}/\text{Cu}$  electrode is 0.34 V.

Given :  $K_{sp} \text{ Cu}(\text{OH})_2 = 1 \times 10^{-20}$

$$\text{Take } \frac{2.303 RT}{F} = 0.059 \text{ V}$$

The reduction potential at pH = 14 for the above couple is  $(-)\text{x} \times 10^{-2} \text{ V}$ .

The value of x is

**Ans.** [25]

**Sol.**  $K_{sp} = 10^{-20} (\text{Cu}^{2+})(1)^2$   
 $[\text{Cu}^{2+}] = 10^{-20}$

$$E_{\text{cell}} = E_{\text{cell}}^{\circ} - \frac{0.059}{2} \log 10^{20}$$

$$E_{\text{cell}} = 0.34 - \frac{0.059}{2} (20)$$

$$= 0.34 - 0.59$$

$$= -0.25$$

$$x = 25$$

- Q.85** See the following chemical reaction:

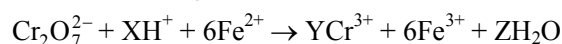

The sum of X, Y and Z is

**Ans.** [23]

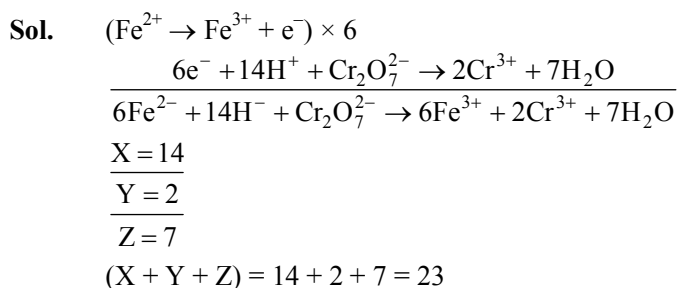

**Q.86** The orbital angular momentum of an electron in 3s orbital is  $\frac{xh}{2\pi}$ . The value of x is \_\_\_\_\_ (nearest integer)

**Ans.** [0]

**Sol.** Orbital angular Momentum

$$\sqrt{\ell(\ell+1)} \frac{h}{2\pi}$$

For s-orbital =  $\lambda = 0$

Orbital angular momentum for s – orbital = 0

**Q.87** Sodium metal crystallizes in a body centred cubic lattice with unit cell edge length of 4 Å. The radius of sodium atom is \_\_\_\_\_  $\times 10^{-1}$  Å. (Nearest integer)

**Ans.** [17]

**Sol.**  $a\sqrt{3} = 4r$

$$4\sqrt{3} = 4 \times r$$

$$r = \sqrt{3} \text{ Å} = 1.73 \text{ Å}$$

$$1.73 = t \times 10^{-1}$$

$$t = 17.3$$

Closest integer = 17

**Q.88**  $\text{A(g)} \rightarrow 2\text{B(g)} + \text{C(g)}$  is a first order reaction. The initial pressure of the system was found to be 800 mm Hg which increased to 1600 mm Hg after 10 min. The total pressure of the system after 30 min will be \_\_\_\_\_ mm Hg. (Nearest integer)

**Ans.** [2200]

**Sol.**



800

$\downarrow x$

$$\begin{array}{ccc} (800-x) & (2x) & (x) \\ 800 + 2x = 1600 & & \end{array}$$

$$2x = 800$$

$$x = 400$$

$$K = \frac{2.303}{10} \log \frac{800}{400} = \frac{2.303 \times \log 2}{10}$$

For 30 min,

$$K = \frac{2.303}{30} \log \frac{(800)}{(800-y)}$$

$$\frac{2.303 \times \log 2}{10} = \frac{2.303}{30} \log \left( \frac{800}{800-y} \right)$$

$$\Rightarrow \left( \frac{800}{800-y} \right) = 8$$

$$100 = 800 - y$$

$$y = 700$$

Total pressure after 30 min

$$(800 - y) + (2y) + (y)$$

$$= 800 + 2y$$

$$= 800 + 1400$$

$$= 2200 \text{ mm Hg}$$

**Q.89** Sea water contains 29.25% NaCl and 19% MgCl<sub>2</sub> by weight of solution. The normal boiling point of the sea water is \_\_\_\_\_ °C (Nearest integer)

Assume 100% ionization for both NaCl and MgCl<sub>2</sub>

Given:  $K_b(\text{H}_2\text{O}) = 0.52 \text{ K kg mol}^{-1}$

Molar mass of NaCl and MgCl<sub>2</sub> is 58.5 and 95 g mol<sup>-1</sup> respectively.

**Ans. [116]**

**Sol.** Molality of solutions

$$\text{NaCl} = \frac{0.5}{51.75} \times 1000$$

$$\text{MgCl}_2 = \frac{0.2}{51.75} \times 1000$$

$$(\Delta T_b) = \{(i_1 m_1) + (i_2 m_2)\} k_b$$

$$\left( \frac{2 \times 0.5 \times 1000}{51.75} + \frac{3 \times 0.2 \times 1000}{51.75} \right) \times 0.52$$

$$= 16.077$$

Boiling point of sea water

$$= 116.077^\circ\text{C}$$

$$\approx 116^\circ\text{C} \text{ (Nearest integer)}$$

**Q.90** 0.400 g of an organic compound (X) gave 0.376 g of AgBr in Carius method for estimation of bromine. % of bromine in the compound (X) is \_\_\_\_\_.

(Given: Molar mass AgBr = 188 g mol<sup>-1</sup> Br = 80 g mol<sup>-1</sup>)

**Ans. [40]**

**Sol.** Moles of AgBr =  $\frac{0.376}{188}$

$$\text{Moles of Br} = \frac{0.376}{188}$$

$$\text{Mass of Br} = \frac{0.376}{188} \times 80$$

$$\% \text{ of Br} = \frac{0.376 \times 80}{188 \times (0.400)} \times 100 = 40\%$$