



## JEE Main Online Exam 2023

### Questions & Solution

11<sup>th</sup> April 2023 | Morning

#### MATHEMATICS

**Section-A:** This section contains 20 multiple choice questions. Each question has 4 choices (1), (2), (3) and (4), out of which **ONLY ONE** is correct..

**Q.1** The number of elements in the set  $S = \{\theta \in [0, 2\pi] : 3 \cos^4\theta - 5\cos^2\theta - 2 \sin^6\theta + 2 = 0\}$  is :  
(1) 10 (2) 8 (3) 12 (4) 9

**Ans.** [4]

**Sol.**  $3\cos^4\theta - 5\cos^2\theta - 2\sin^6\theta + 2 = 0$   
 $\Rightarrow \cos^2\theta[3\cos^2\theta - 5] - 2\sin^6\theta + 2 = 0$   
 $\Rightarrow (1 - \sin^2\theta)(3 - 3\sin^2\theta - 5) - 2\sin^6\theta + 2 = 0$   
 $\Rightarrow (\sin^2\theta - 1)(3\sin^2\theta + 2) - 2\sin^6\theta + 2 = 0$   
Let  $\sin^2\theta = t$   
 $(t - 1)(3t + 2) - 2t^3 + 2 = 0$   
 $(t - 1)[3t + 2 - 2(t^2 + t + 1)] = 0$   
 $(t - 1)[2t^2 - t] = 0$

$$t = 0, 1, \frac{1}{2}$$

$$\therefore \sin^2\theta = 0 \rightarrow 3 \text{ solution}$$

$$\sin^2\theta = 1 \rightarrow 2 \text{ solution}$$

$$\sin^2\theta = \frac{1}{2} \rightarrow 4 \text{ solution}$$

$$\therefore \text{Total solution} = 9$$

**Q.2** Let  $f : [2, 4] \rightarrow \mathbb{R}$  be a differentiable function such that  $(x \log_e x)f'(x) + (\log_e x)f(x) + f(x) \geq 1, x \in [2, 4]$

$$\text{with } f(2) = \frac{1}{2} \text{ and } f(4) = \frac{1}{2}.$$

Consider the following two statements :

(A)  $f(x) \leq 1$ , for all  $x \in [2, 4]$

(B)  $f(x) \geq \frac{1}{8}$ , for all  $x \in [2, 4]$

Then,

(1) Neither statement (A) nor statement (B) is true

(2) Only statement (B) is true

(3) Both the statements (A) and (B) are true

(4) Only statement (A) is true

**Ans.** [3]

**Sol.**  $f : [2, 4] \rightarrow \mathbb{R}$

$$(x \log_e x) f'(x) + (\log_e x) f(x) + f(x) \geq 1, x \in [2, 4]$$

$$\Rightarrow d[x \ln x f(x) - x] \geq 0 \text{ OR } d(x \ln x \cdot f(x)) \geq 1$$

$$\therefore h(x) = x \ln x f(x) - x \uparrow$$

$$\therefore h(x) \geq h(2), x \in [2, 4]$$

$$x \ln x f(x) - x \geq 2 \ln 2 f(2) - 2$$

$$\Rightarrow x \ln x f(x) - x \geq \ln 2 - 2, x \ln x f(x) - x \leq \ln 4 - 4$$

So,

$$\frac{\ln 2 - 2}{x \ln x} + \frac{1}{\ln x} \leq f(x) \leq \frac{\ln 4 - 4}{x \ln x} + \frac{1}{\ln x}$$

$$f(x) \leq 1$$

$$\& f(x) \geq \frac{1}{8}$$

Hence both A & B are correct.

But LMVT on  $f(x) \cdot x \ln x$  can't be satisfied. Hence no such  $f(x)$  exist.

**Q.3** Let R be a rectangle given by the lines  $x = 0, x = 2, y = 0$  and  $y = 5$ . Let  $A(\alpha, 0)$  and  $B(0, \beta), \alpha \in [0, 2]$  and  $\beta \in [0, 5]$ , be such that the line segment AB divides the area of the rectangle R in the ratio 4 : 1. Then, the mid-point of AB lies on a

- (1) straight line                      (2) parabola                      (3) hyperbola                      (4) circle

**Ans.**

[3]

**Sol.**

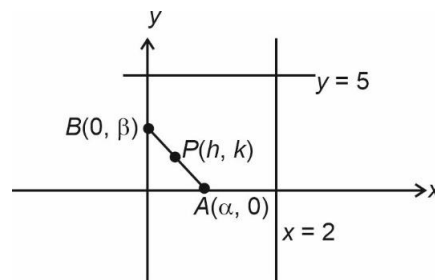

$$\frac{10 - \frac{1}{2}\alpha\beta}{\frac{1}{2}\alpha\beta} = \frac{4}{1} \Rightarrow 20 - \alpha\beta = 4\alpha\beta$$

$$\Rightarrow \boxed{\alpha\beta = 4}$$

$$\text{Let } h = \frac{\alpha}{2}, \beta = \frac{k}{2}$$

$$\therefore 4hk = 4$$

$$\therefore \boxed{xy = 1}$$

**Q.4** Let  $S = \{M = [a_{ij}], a_{ij} \in \{0, 1, 2\}, \{1 \leq i, j \leq 2\}\}$  be a sample space and  $A = \{M \in S : M \text{ is invertible}\}$  be an event. Then  $P(A)$  is equal to

- (1)  $\frac{16}{27}$                       (2)  $\frac{47}{81}$                       (3)  $\frac{49}{81}$                       (4)  $\frac{50}{81}$

**Ans.**

[4]

**Sol.**

If M is invertible, then  $|M| \neq 0$

For  $|M| = 0$

1.  $\begin{bmatrix} 1 & 1 \\ 1 & 1 \end{bmatrix}$  or  $\begin{bmatrix} 0 & 0 \\ 0 & 0 \end{bmatrix}$  or  $\begin{bmatrix} 2 & 2 \\ 2 & 2 \end{bmatrix} \rightarrow$  Total matrix = 3

2. Two 1's and Two 0's  $\rightarrow$  Total matrix = 4

3. Two 2's and Two 0's  $\rightarrow$  Total matrix = 4

4. Two 1's and Two 2's  $\rightarrow$  Total matrix = 4

5. One 1 and three 0's  $\rightarrow$  Total matrix = 4

6. One 2 and Three 0's  $\rightarrow$  Total matrix = 4

7. One 1 and one 2 and two 0's  $\rightarrow$  Total matrix = 8

$$P(A) = 1 - \frac{31}{81} = \frac{50}{81}$$

**Q.5** The number of integral solution  $x$  of  $\log_{\left(x+\frac{7}{2}\right)}\left(\frac{x-7}{2x-3}\right)^2 \geq 0$  is :

(1) 7

(2) 8

(3) 6

(4) 5

**Ans.** [3]

**Sol.**  $\log_{\left(x+\frac{7}{2}\right)}\left(\frac{x-7}{2x-3}\right)^2 \geq 0$

Domain

$$x + \frac{7}{2} > 0$$

$$x > -\frac{7}{2}$$

$$x + \frac{7}{2} \neq 1$$

$$x \neq -\frac{5}{2}$$

$$\frac{x-7}{2x-3} \neq 0$$

$$x \neq 7$$

$$x \neq \frac{3}{2}$$

$$\text{Domain } \left(-\frac{7}{2}, \infty\right) - \left(\frac{-5}{2}, 0, \frac{3}{2}\right)$$

**Case I :**  $0 < x + \frac{7}{2} < 1$

$$-\frac{7}{2} < x < -\frac{5}{2}$$

$$\left(\frac{x-7}{2x-3}\right)^2 \leq 1$$

$$-1 \leq \frac{x-7}{2x-3} \leq 1$$

$$\frac{x-7+2x-3}{2x-3} \geq 0$$

$$\frac{3x-10}{2x-3} \geq 0$$

+	-	+
$\frac{3}{2}$	$\frac{10}{3}$	

$$\frac{x-7-2x+3}{2x-3} \leq 0$$

$$\frac{-x-4}{2x-3} \leq 0$$

$$\frac{x+4}{2x-3} \geq 0$$





$$\text{Var}(x_1 - 3, x_2 - 3, \dots, x_5 - 3) = 12$$

$$\frac{\sum (x_i - 3)^2}{5} - 4 = 12$$

**B**

$$\text{mean}(y_1, y_2, \dots, y_5) = 8$$

$$\Rightarrow \text{mean}(y_1 + 2, y_2 + 2, \dots, y_5 + 2) = 10$$

$$\text{Var}(y_1, y_2, \dots, y_5) = 20$$

$$\text{Var}(y_1 + 2, y_2 + 2, \dots, y_5 + 2) = 20$$

$$\frac{\sum (y_i - 2)^2}{5} - 100 = 20$$

$$\text{Combined mean} = \frac{\sum_{i=1}^5 (x_i - 3) + \sum (y_i + 2)}{10}$$

$$= \frac{10 + 50}{10} = 6$$

Combined variance

$$= \frac{\sum (x_i - 3)^2 + \sum (y_i + 2)^2 - 6^2}{10}$$

$$= \frac{80 + 120 \times 5}{10} - 36 = 32$$

**Q.9** Let  $(\alpha, \beta, \gamma)$  be the image of point P (2, 3, 5) in the plane  $2x + y - 3z = 6$ . Then  $\alpha + \beta + \gamma$  is equal to :  
(1) 5 (2) 10 (3) 12 (4) 9

**Ans.** [2]

$$\text{Sol.} \quad \frac{\alpha - 2}{2} = \frac{\beta - 3}{1} = \frac{\gamma - 5}{-3} = -2 \frac{(4 + 3 - 15 - 6)}{14} = 2$$

$$\Rightarrow \frac{\alpha - 2}{2} = 2 \Rightarrow \alpha = 6$$

$$\frac{\beta - 3}{1} = 2 \Rightarrow \beta = 5$$

$$\frac{\gamma - 5}{-3} = 2 \Rightarrow \gamma = -1$$

$$\therefore \alpha + \beta + \gamma = 6 + 5 - 1 = 10$$

Option (2) is correct

**Q.10** Let  $f(x) = [x^2 - x] + |-x + [x]|$ , where  $x \in \mathbb{R}$  and  $[t]$  denotes the greatest integer less than or equal to  $t$ . Then,  $f$  is :

- (1) continuous at  $x = 0$ , but not continuous at  $x = 1$
- (2) continuous at  $x = 1$ , but not continuous at  $x = 0$
- (3) continuous at  $x = 0$  and  $x = 1$
- (4) not continuous at  $x = 0$  and  $x = 1$

**Ans.** [2]

$$\begin{aligned} \text{Sol.} \quad f(x) &= [x^2 - x] + |-x + [x]| \\ &= [x^2 - x] + |x - [x]| \\ &= [x^2 - x] + |\{x\}| \\ &= [x^2 - x] + |x| \quad (\because \{x\} \geq 0) \\ &\text{at } x = 0 \\ f(0) &= 0 \end{aligned}$$

$f(0^+) = -1$   
 $\therefore$  discontinuous at  $x = 0$   
 at  $x = 1$   
 $f(1) = 0$   
 $f(1^+) = 0 + 0 = 0$   
 $f(1^-) = -1 + 1 = 0$   
 $\therefore$  Continuous at  $x = 1$   
 Option (2) is correct.

**Q.11** For any vector  $\vec{a} = a_1 \hat{i} + a_2 \hat{j} + a_3 \hat{k}$ , with  $10|a_i| < 1, i = 1, 2, 3$ , consider the following statements:

- (A) :  $\max\{|a_1|, |a_2|, |a_3|\} \leq \vec{a}$  (B) :  $|a| \leq 3 \max\{|a_1|, |a_2|, |a_3|\}$   
 (1) Only (B) is true (2) Only (A) is true  
 (3) Both (A) and (B) are true (4) Neither (A) nor (B) is true

**Ans.** [3]

**Sol.**  $|\vec{a}| = \sqrt{a_1^2 + a_2^2 + a_3^2} \geq \max\{|a_1|, |a_2|, |a_3|\}$   
 $\therefore$  Statement – A is true  
 $|\vec{a}| = \sqrt{a_1^2 + a_2^2 + a_3^2} \leq 3 \max\{|a_1|, |a_2|, |a_3|\}$   
 Statement – B is true  
 $\therefore$  Option (3) is correct.

**Q.12** Area of the region  $\{(x, y) : x^2 + (y - 2)^2 \leq 4, x^2 \geq 2y\}$  is :

- (1)  $\pi + \frac{8}{3}$  (2)  $2\pi + \frac{16}{3}$  (3)  $\pi - \frac{8}{3}$  (4)  $2\pi - \frac{16}{3}$

**Ans.** [4]

**Sol.**  $x^2 + (y - 2)^2 \leq 4, x^2 \geq 2y$

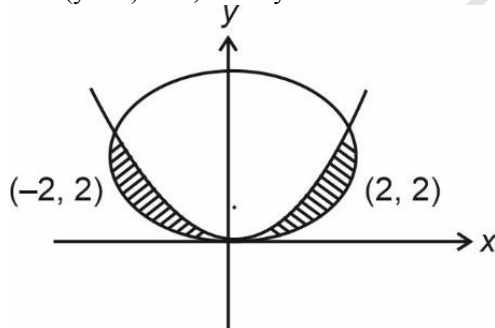

$$\text{Area of required region} = 2 \left[ \frac{1}{4} \pi (4) - \int_0^2 \sqrt{2} - \sqrt{y} \, dy \right]$$

$$\Rightarrow 2 \left| \pi - \frac{\sqrt{2} \cdot y^{3/2}}{3/2} \right|_0^2$$

$$\Rightarrow 2 \left| \pi - \frac{2\sqrt{2}}{3} \cdot 2\sqrt{2} \right| = 2 \left| \pi - \frac{8}{3} \right| = 2\pi - \frac{16}{3}$$

Option (4) is correct.

**Q.13** If the equation of the plane that contains the point  $(-2, 3, 5)$  and is perpendicular to each of the planes  $2x + 4y + 5z = 8$  and  $3x - 2y + 3z = 5$  is  $\alpha x + \beta y + \gamma z + 97 = 0$  then  $\alpha + \beta + \gamma =$

- (1) 15 (2) 18 (3) 16 (4) 17

**Ans.** [1]

**Sol.**  $P : \alpha x + \beta y + \gamma z + 97 = 0$   
 $-2\alpha + 3\beta + 5\gamma + 97 = 0 \quad \dots(1)$   
 $2\alpha + 4\beta + 5\gamma = 0 \quad \dots(2)$   
 $3\alpha - 2\beta + 3\gamma = 0 \quad \dots(3)$   
From (1), (2), (3)  
 $\alpha = 22 \quad \beta = 9 \quad \gamma = -16$   
 $\alpha + \beta + \gamma = 22 + 9 - 16$   
 $= 15$

**Q.14** The number of triplets  $(x, y, z)$  where  $x, y, z$  are distinct non negative integers satisfying  $x + y + z = 15$ , is :  
(1) 80 (2) 136 (3) 114 (4) 92

**Ans.** [3]

**Sol.**  $x + y + z = 15$   
Total =  ${}^{15+3-1}C_{3-1} = {}^{17}C_2$   
If any of these 2 are equal  
 $x + 2y = 15$   
For  $y = 0 \quad x = 15$   
 $y = 1 \quad x = 13$   
 $y = 2 \quad x = 11$   
 $y = 3 \quad x = 9$   
 $y = 4 \quad x = 7$   
 $y = 5 \quad x = 5 \rightarrow x = y = z = 5$   
 $y = 6 \quad x = 3$   
 $y = 7 \quad x = 1$   
 $\therefore$  Total =  ${}^{17}C_2 - {}^3C_2 \times 8 + 2$   
 $= 136 - 24 + 2 = 114$

**Q.15** Let  $y = y(x)$  be a solution curve of the differential equation.

$$(1 - x^2y^2)dx = ydx + xdy.$$

If the line  $x = 1$  intersects the curve  $y = y(x)$  at  $y = 2$  and the line  $x = 2$  intersects the curve  $y = y(x)$  at  $y = \alpha$ , then a value of  $\alpha$  is

(1)  $\frac{1 - 3e^2}{2(3e^2 + 1)}$  (2)  $\frac{1 + 3e^2}{2(3e^2 + 1)}$  (3)  $\frac{3e^2}{2(3e^2 - 1)}$  (4)  $\frac{3e^2}{2(3e^2 + 1)}$

**Ans.** [2]

**Sol.**  $dx = \frac{d(yx)}{1 - (xy)^2}$   
 $2dx = \frac{d(xy)}{1 - xy} + \frac{d(xy)}{1 - xy}$   
 $2x + c = \ln \left| \frac{1 + xy}{1 - xy} \right|$   
 $\Rightarrow \left| \frac{xy + 1}{xy - 1} \right| e^c e^{2x}$   
 $y(1) = 2$   
 $3 = e^c e^2$   
 $e^c = \frac{3}{e^2}$   
 $\left| \frac{xy + 1}{xy - 1} \right| = 3e^{2x-2}$



$$\text{Now } y(2) = \left| \frac{2y+1}{2y-1} \right| = 3e^2$$

$$2y+1 = 2 \cdot 3e^2 y - 3e^2$$

$$1 + 3e^2 \Rightarrow 2y(3e^2 - 1)$$

$$y(2) = \frac{1+3e^2}{2(3e^2-1)}$$

**Q.16** Let  $\vec{a}$  be a non-zero vector parallel to the line of intersection of the two planes described by  $\hat{i} + \hat{j}$ ,  $\hat{i} + \hat{k}$  and  $\hat{i} - \hat{j}$ ,  $\hat{j} - \hat{k}$ . If  $\theta$  is the angle between the vector  $\vec{a}$  and the vector  $\vec{b} = 2\hat{i} - 2\hat{j} + \hat{k}$  and  $\vec{a} \cdot \vec{b} = 6$ , then the ordered pair  $(\theta, |\vec{a} \times \vec{b}|)$  is equal to :

- (1)  $\left(\frac{\pi}{3}, 3\sqrt{6}\right)$                       (2)  $\left(\frac{\pi}{4}, 3\sqrt{6}\right)$                       (3)  $\left(\frac{\pi}{3}, 6\right)$                       (4)  $\left(\frac{\pi}{4}, 6\right)$

**Ans.** [4]

**Sol.** 
$$\begin{vmatrix} \hat{i} & \hat{j} & \hat{k} \\ 1 & 1 & 0 \\ 1 & 0 & 1 \end{vmatrix} = \hat{i} - \hat{j} - \hat{k}$$

$$\begin{vmatrix} \hat{i} & \hat{j} & \hat{k} \\ 1 & -1 & 0 \\ 1 & 0 & -1 \end{vmatrix} = \hat{i} + \hat{j} + \hat{k}$$

$$\text{direction of } \vec{a} = \begin{vmatrix} \hat{i} & \hat{j} & \hat{k} \\ 1 & -1 & -1 \\ 1 & 1 & 1 \end{vmatrix}$$

$$= -2\hat{j} + 2\hat{k}$$

$$\text{Dir's of } \vec{a} = \langle 0, -1, 1 \rangle$$

$$\vec{b} = 2\hat{i} + 2\hat{j} + \hat{k}$$

$$\vec{a} = \lambda(-\hat{j} + \hat{k})$$

$$\vec{a} \cdot \vec{b} = 6 = \lambda(2+1)$$

$$\lambda = 2$$

$$\therefore \vec{a} = -2\hat{j} + 2\hat{k}$$

$$\text{Now } \vec{a} \cdot \vec{b} = |\vec{a}| |\vec{b}| \cos\theta$$

$$6 = 2\sqrt{2} \times 3 \cos\theta$$

$$\cos\theta = \frac{1}{\sqrt{2}}$$

$$\theta = \frac{\pi}{4}$$

$$|\vec{a} \times \vec{b}| = 2\sqrt{2} \times 3 \times \frac{1}{\sqrt{2}} = 6$$

**Q.17** Let  $w_1$  be the point obtained by the rotation of  $z_1 = 5 + 4i$  about the origin through a right angle in the anticlockwise direction, and  $w_2$  be the point obtained by the rotation of  $z_2 = 3 + 5i$  about the origin through a right angle in the clockwise direction. Then the principal argument  $w_1 - w_2$  is equal to :

- (1)  $\pi - \tan^{-1} \frac{8}{9}$                       (2)  $-\pi + \tan^{-1} \frac{33}{5}$                       (3)  $-\pi + \tan^{-1} \frac{8}{9}$                       (4)  $\pi - \tan^{-1} \frac{33}{5}$

**Ans.** [1]

**Sol.**  $w_1 = iz_1 = i(5 + 4i) = -4 + 5i$   
 $w_2 = -iz_2 = -i(3 + 5i) = 5 - 3i$   
 $w_1 - w_2 = -9 + 8i$   
 $-1 \ 8$   
 $\arg = \pi - \tan^{-1} \frac{8}{9}$

**Q.18** Let  $x_1, x_2, \dots, x_{100}$  be in an arithmetic progression, with  $x_1 = 2$  and their mean equal to 200. If  $y_i = i(x_i - i)$ ,  $1 \leq i \leq 100$ , then the mean of  $y_1, y_2, \dots, y_{100}$  is :

- (1) 10100                      (2) 10101.50                      (3) 10049.50                      (4) 10051.50

**Ans.** [3]

**Sol.**  $\sum x_i = 100 \times 200$

$$\frac{100}{2}(x_1 + x_{100}) = 100 \times 200$$

$$x_{100} = 398$$

$$x_1 + 99d = 398$$

$$d = 4$$

$$x_i = 2 + (i - 1)4 = 4i - 2$$

$$\Rightarrow \bar{y} = \frac{1}{100} \sum y_i = \frac{1}{100} \sum_i (x_i - i)$$

$$\bar{y} = \frac{1}{100} \sum_i (4i - 2 - i) = \frac{1}{100} \sum_i (3i - 2)$$

$$= \frac{1}{100} \left[ 3 \times \frac{100 \times 101 \times 201}{6} - 2 \frac{100 \times 101}{2} \right] = \left[ \frac{101 \times 201}{2} - 101 \right] = 10049.5$$

**Q.19** Consider ellipses  $E_k : kx^2 + ky^2 = 1$ ,  $k = 1, 2, \dots, 20$ . Let  $C_k$  be the circle which touches the four chords joining the end points (one on minor axis and another on major axis) of the ellipse  $E_k$ . If  $r_k$  is the radius of the circle

$C_k$ , then the value of  $\sum_{k=1}^{20} \frac{1}{r_k^2}$  is :

- (1) 3080                      (2) 2870                      (3) 3210                      (4) 3320

**Ans.** [1]

**Sol.**  $E_k = \frac{x^2}{\left(\frac{1}{\sqrt{k}}\right)^2} + \frac{y^2}{\left(\frac{1}{k}\right)^2} = 1$

Chord

$$L_k : \frac{x}{\left(\frac{1}{\sqrt{k}}\right)} + \frac{y}{\left(\frac{1}{k}\right)} = 1$$

$$\Rightarrow \sqrt{k}x + ky - 1 = 0$$

$r_k =$  Perpendicular distance of  $L_k$  from  $(0, 0)$ .

$$r_k = \frac{|-1|}{\sqrt{k + k^2}}$$

$$\Rightarrow r_k^2 = \frac{1}{k + k^2}$$

$$\sum_{k=1}^{20} \frac{1}{r_k^2} = \sum_{k=1}^{20} (k + k^2) = \frac{20 \times 21}{2} + \frac{20 \times 21 \times 41}{6} = 210 + 2870 = 3080$$



**Q.22** Let  $H_n : \frac{x^2}{1+n} - \frac{y^2}{3+n} = 1, n \in \mathbb{N}$ . Let  $k$  be the smallest even value of  $n$  such that the eccentricity of  $H_k$  is a rational number. If  $l$  is the length of the latus rectum of  $H_k$ , then  $21l$  is equal to \_\_\_\_\_.

**Ans.** [306]

**Sol.**  $(3+n) = (1+n)(e^2-1)$

$$e^2 = \frac{2n+4}{n+1} = \frac{2(n+2)}{n+1}$$

Check when  $(n+1) = 9, 25, 49, \dots$

$$n=8, e^2 = \frac{20}{9}$$

$$n=24, e^2 = \frac{52}{25}$$

$$n=48, e^2 = \frac{100}{49} \Rightarrow e = \frac{10}{7}$$

$$\Rightarrow n=48$$

$$\Rightarrow 21l = 21 \times \frac{2b^2}{a} = 42 \times \frac{n+3}{\sqrt{n+1}} = \frac{42 \times 51}{7} = 306$$

**Q.23** If  $a$  and  $b$  are the roots of the equation  $x^2 - 7x - 1 = 0$ , then the value of  $\frac{a^{21} + b^{21} + a^{17} + b^{17}}{a^{19} + b^{19}}$  is equal to \_\_\_\_\_.

**Ans.** [51]

**Sol.**  $x^2 - 7x - 1 = 0$

$$\Rightarrow a^2 - 7a - 1 = 0$$

$$\Rightarrow a - \frac{1}{a} = 7$$

$$\Rightarrow a^2 + \frac{1}{a^2} = 51$$

$$\text{Similarly } b^2 + \frac{1}{b^2} = 51$$

$$\Rightarrow \frac{a^{21} + b^{21} + a^{17} + b^{17}}{a^{19} + b^{19}}$$

$$= \frac{a^{19} \left( a^2 + \frac{1}{a^2} \right) + b^{19} \left( b^2 + \frac{1}{b^2} \right)}{a^{19} + b^{19}} = 51$$

**Q.24** Let a line  $l$  pass through the origin and be perpendicular to the lines

$$l_1 : \vec{r} = (\hat{i} - 11\hat{j} - 7\hat{k}) + \lambda(\hat{i} + 2\hat{j} + 3\hat{k}), \lambda \in \mathbb{R} \text{ and}$$

$$l_2 : \vec{r} = (-\hat{i} + \hat{k}) + \mu(2\hat{i} + 2\hat{j} + \hat{k}), \mu \in \mathbb{R}$$

If  $P$  is the point of intersection of  $l$  and  $l_1$ , and  $Q(\alpha, \beta, \gamma)$  is the foot of perpendicular from  $P$  on  $l_2$ , then  $9(\alpha + \beta + \gamma)$  is equal to \_\_\_\_\_.

**Ans. [05.00]**

**Sol.** For direction of line

$$\begin{vmatrix} \hat{i} & \hat{j} & \hat{k} \\ 1 & 2 & 3 \\ 2 & 2 & 1 \end{vmatrix} = \hat{i}(-4) - \hat{j}(-5) + \hat{k}(-2) = -4\hat{i} + 5\hat{j} - 2\hat{k}$$

$$l: \vec{r} = \mu(-4\hat{i} + 5\hat{j} - 2\hat{k})$$

For P

$$1 + \lambda = -4\mu$$

$$-11 + 2\lambda = 5\mu$$

$$-7 + 3\lambda = -2\mu$$

$$\text{So, } 1 + \lambda = -14 + 6\lambda \Rightarrow \lambda = 3, \mu = -1$$

$$P \equiv (4, -5, 2)$$

$$2(-5 + 2\mu) + 2(2\mu + 5) + 1(\mu - 1) = 0$$

$$\mu = \frac{1}{9}$$

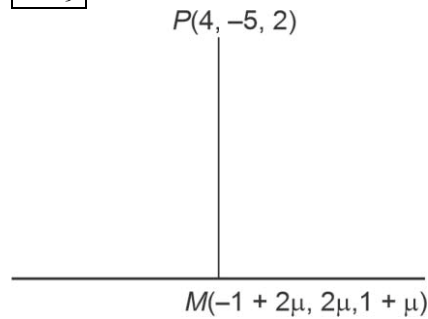

$$\alpha + \beta + \gamma = 5\mu = \frac{5}{9}$$

**Q.25** The number of integral terms in the expansion of  $\left(3^{\frac{1}{2}} + 5^{\frac{1}{4}}\right)^{680}$  is equal to

**Ans. [171.00]**

**Sol.**  $T_{r+1} = {}^{680}C_r 3^{340\frac{r}{2}} 5^{\frac{r}{4}}$   
 $r = 4\lambda$   
 Total (171) terms

**Q.26** In an examination, 5 students have been allotted their seats as per their roll numbers. The number of ways, in which none of the students sits on the allotted seat, is \_\_\_\_\_.

**Ans. [44.00]**

**Sol.** Number of ways

$$= D_5 = 5! \left(1 - \frac{1}{1!} + \frac{1}{2!} - \frac{1}{3!} + \frac{1}{4!} - \frac{1}{5!}\right) = 44$$

**Q.27** Let  $A = \begin{bmatrix} 0 & 1 & 2 \\ a & 0 & 3 \\ 1 & c & 0 \end{bmatrix}$ , where  $a, c \in \mathbb{R}$ . If  $A^3 = A$  and the positive value of  $a$  belongs to the interval  $(n-1, n]$ ,

where  $n \in \mathbb{N}$ , then  $n$  is equal to \_\_\_\_\_.

**Ans. [02.00]**

$$\text{Sol. } A^2 = \begin{bmatrix} 0 & 1 & 2 \\ \alpha & 0 & 3 \\ 1 & c & 0 \end{bmatrix} \begin{bmatrix} 0 & 1 & 2 \\ \alpha & 0 & 3 \\ 1 & c & 0 \end{bmatrix} = \begin{bmatrix} \alpha+2 & 2c & 3 \\ 3 & \alpha+3c & 2\alpha \\ c\alpha & 1 & 2+3c \end{bmatrix}$$

$$A^3 = \begin{bmatrix} \alpha+2 & 2c & 3 \\ 3 & \alpha+3c & 2\alpha \\ c\alpha & 1 & 2+3c \end{bmatrix} \begin{bmatrix} 0 & 1 & 2 \\ \alpha & 0 & 3 \\ 1 & c & 0 \end{bmatrix} = \begin{bmatrix} 2c\alpha+3 & \alpha+2+3c & 2\alpha+4+6c \\ \alpha^2+3c\alpha+2\alpha & 3+2\alpha c & 6+3\alpha+9c \\ \alpha+2+3c & c\alpha+2c+3c^2 & 2c\alpha+3 \end{bmatrix}$$

$$2c\alpha + 3 = 0, \alpha + 2 + 3c = 1$$

$$\alpha + 2 + 3 \left( \frac{-3}{2\alpha} \right) = 1$$

$$\alpha + 1 - \frac{9}{2\alpha} = 0$$

$$2\alpha^2 + 2\alpha - 9 = 0$$

$$a \in (1, 2)$$

**Q.28** The mean of the coefficients of  $x, x^2, \dots, x^7$  in the binomial expression of  $(2+x)^9$  is \_\_\_\_\_.**Ans. [2736]**

$$\text{Sol. } {}^9C_1 2^8 \cdot x + {}^9C_2 2^7 \cdot x^2 + \dots + {}^9C_7 2^0 \cdot x^7 = (2+x)^9 - {}^9C_0 2^9 - {}^9C_8 2 \cdot x^8 - {}^9C_9 \cdot x^9 \quad \dots(i)$$

Sum of coefficients of  $x, x^2, \dots, x^7$ 

$$= 3^9 - 2^9 - 18 - 1 = 19152$$

$$\text{Required mean} = \frac{19152}{7} = 2736$$

**Q.29** Let  $S = 109 + \frac{108}{5} + \frac{107}{5^2} + \dots + \frac{2}{5^{107}} + \frac{1}{5^{108}}$ . Then the value of  $(16S - (25)^{-54})$  is equal to \_\_\_\_\_.**Ans. [2175]**

$$\text{Sol. } S = 109 + \frac{108}{5} + \frac{107}{5^2} + \dots + \frac{2}{5^{107}} + \frac{1}{5^{108}} \quad \dots(i)$$

$$\frac{S}{5} = \frac{109}{5} + \frac{108}{5^2} + \dots + \frac{2}{5^{108}} + \frac{1}{5^{109}} \quad \dots(ii)$$

Equation (ii) - (i) gives

$$\frac{-4S}{5} = -109 + \left( \frac{1}{5} + \frac{1}{5^2} + \dots + \frac{1}{5^{108}} + \frac{1}{5^{109}} \right)$$

$$\frac{-4S}{5} = -109 + \frac{1 \left( 1 - \left( \frac{1}{5} \right)^{109} \right)}{1 - \frac{1}{5}}$$

$$\frac{4S}{5} = -109 + \frac{1}{4} \left( 1 - \frac{1}{5^{109}} \right)$$

$$\Rightarrow 16S - (25)^{-54} = 2175$$

**Q.30** The number of ordered triplets of the truth values of p, q and r such that the truth value of the statement  $(p \vee q) \wedge (p \vee r) \Rightarrow (q \vee r)$  is True, is equal to \_\_\_\_\_.

**Ans.** [7]

**Sol.**  $(p \vee q) \wedge (p \vee r) \Rightarrow (q \vee r)$   
 $\Rightarrow p \vee (q \wedge r) \Rightarrow (q \vee r)$

This is always true (T) if  $p \vee (q \wedge r)$  is false (F)

$\Rightarrow (p, q, r) \equiv (F, F, F), (F, F, T), (F, T, F)$

Again, this is true if  $p \vee (q \wedge r)$  is T and  $q \vee r$  is T

$\therefore (p, q, r) \equiv (F, T, T), (T, T, T), (T, F, T), (T, T, F)$

$\therefore$  7 triplet are possible

---

## PHYSICS

---

**Section-A:** Multiple Choice Questions: This section contains 20 multiple choice questions. Each question has 4 choices (1), (2), (3) and (4), out of which **ONLY ONE** is correct.

---

**Q.31** The radii of two planets 'A' and 'B' are 'R' and '4R' and their densities are  $\rho$  and  $\rho/3$  respectively. The ratio of acceleration due to gravity at their surfaces ( $g_A : g_B$ ) will be :

(1) 4 : 3

(2) 1 : 16

(3) 3 : 16

(4) 3 : 4

**Ans.** [4]

**Sol.**  $g \propto \rho R$

$$\frac{g_A}{g_B} = \left( \frac{\rho_A}{\rho_B} \times \frac{R_A}{R_B} \right) = (3) \times \frac{1}{4} = \left( \frac{3}{4} \right)$$

**Q.32** The free space inside a current carrying toroid is filled with a material of susceptibility  $2 \times 10^{-2}$ . The percentage increase in the value of magnetic field inside the toroid will be :

(1) 0.2%

(2) 0.1%

(3) 2%

(4) 1%

**Ans.** [3]

**Sol.**  $\frac{\Delta B}{B_0} = \chi$

$$\frac{\Delta B}{B_0} \times 100 = (2 \times 10^{-2}) \times 100 = 2\%$$

**Q.33** Three vessels of equal volume contain gases at the same temperature and pressure. The first vessel contains neon (monoatomic), the second contains chlorine (diatomic) and third contains uranium hexafluoride (polyatomic). Arrange these on the basis of their root mean square speed ( $v_{rms}$ ) and choose the correct answer from the options given below:

(1)  $v_{rms}(\text{mono}) > v_{rms}(\text{dia}) > v_{rms}(\text{poly})$

(2)  $v_{rms}(\text{mono}) = v_{rms}(\text{dia}) = v_{rms}(\text{poly})$

(3)  $v_{rms}(\text{mono}) < v_{rms}(\text{dia}) < v_{rms}(\text{poly})$

(4)  $v_{rms}(\text{dia}) < v_{rms}(\text{poly}) < v_{rms}(\text{mono})$

**Ans.** [1]

**Sol.**  $v_{rms}$  is same for all, if mass and temperature is same,

$$v_{rms} \propto \frac{1}{\sqrt{M}}$$

$$v_{\text{poly}} < v_{\text{dia}} < v_{\text{mono}}$$

**Q.34** Two radioactive elements A and B initially have same number of atoms. The half life of A is same as the average life of B. If  $\lambda_A$  and  $\lambda_B$  are decay constants of A and B respectively, then choose the correct relation from the given options.

- (1)  $\lambda_A \ln 2 = \lambda_B$                       (2)  $\lambda_A = \lambda_B$                       (3)  $\lambda_A = \lambda_B \ln 2$                       (4)  $\lambda_A = 2\lambda_B$

**Ans.** [3]

**Sol.** 
$$\frac{m^2}{\lambda_A} = \left( \frac{1}{\lambda_B} \right)$$

$$\lambda_A = \lambda_B \ln 2$$

**Q.35** The electric field in an electromagnetic wave is given as

$$\vec{E} = 20 \sin \omega \left( t - \frac{x}{c} \right) \vec{j} \text{ NC}^{-1}$$

where  $\omega$  and  $c$  are angular frequency and velocity of electromagnetic wave respectively. The energy contained in a volume of  $5 \times 10^{-4} \text{ m}^3$  will be (Given  $\epsilon_0 = 8.85 \times 10^{-12} \text{ C}^2/\text{Nm}^2$ )

- (1)  $88.5 \times 10^{-13} \text{ J}$                       (2)  $17.7 \times 10^{-13} \text{ J}$                       (3)  $28.5 \times 10^{-13} \text{ J}$                       (4)  $8.85 \times 10^{-13} \text{ J}$

**Ans.** [4]

**Sol.** 
$$E_{\text{total}} = \frac{1}{2} \epsilon_0 E_0^2 \times \text{volume} = \frac{1}{2} 8.85 \times 10^{-12} \times (20)^2 \times 5 \times 10^{-4} = 8.85 \times 10^{-13} \text{ J}$$

**Q.36** A metallic surface is illuminated with radiation of wavelength  $\lambda$ , the stopping potential is  $V_0$ . If the same surface is illuminated with radiation of wavelength  $2\lambda$ , the stopping potential becomes  $\frac{V_0}{4}$ . The threshold wavelength for this metallic surface will be :

- (1)  $3\lambda$                       (2)  $4\lambda$                       (3)  $\frac{3}{2}\lambda$                       (4)  $\frac{\lambda}{4}$

**Ans.** [1]

**Sol.** 
$$V_0 = \frac{hc}{\lambda_0} - \phi \quad \dots(1)$$

$$\frac{V_0}{4} = \frac{hc}{2\lambda_0} - \phi \quad \dots(2)$$

$$\Rightarrow V_0 - \frac{V_0}{2} = -\phi + 2\phi$$

$$\phi = \left( \frac{V_0}{2} \right) \Rightarrow \frac{hc}{\lambda_0} = \left( \frac{3V_0}{2} \right)$$

$$\frac{hc}{\lambda_{\text{th}}} = \frac{1}{2} \times \frac{2hc}{3\lambda_0}$$

$$V_0 = \left( \frac{2hc}{3\lambda_0} \right)$$

$$\lambda_{\text{th}} = (3\lambda_0)$$

**Q.37** Two identical heater filaments are connected first in parallel and then in series. At the same applied voltage, the ratio of heat produced in same time for parallel to series will be :

- (1) 1 : 4                      (2) 4 : 1                      (3) 2 : 1                      (4) 1 : 2

**Ans.** [2]



**Sol.**  $P_1 = \left(\frac{V^2}{2R}\right)$  for series

$$P_2 = \frac{V^2}{\left(\frac{R}{2}\right)} = \left(\frac{2V^2}{R}\right)$$

$$\Rightarrow \frac{P_2}{P_1} = \left(\frac{4}{1}\right)$$

**Q.38** Form the v-t graph shown, the ratio of distance to displacement in 25 s of motion is:

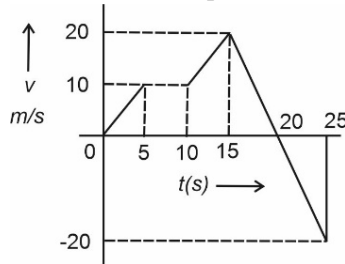

- (1) 1                                      (2)  $\frac{1}{2}$                                       (3)  $\frac{5}{3}$                                       (4)  $\frac{3}{5}$

**Ans.** [3]

**Sol.** (Area) =  $\frac{1}{2} \times 5 \times 10 + 5 \times 10 + \frac{1}{2} \times 30 \times 5 + \frac{1}{2} \times 20 \times 5 - \frac{1}{2} \times 20 \times 5$

Net area = 25 + 50 + 75 + 50 – 50

Displacement = 150 m

Distance = (200 + 50)

= 250 m

$$\frac{\text{distance}}{\text{displacement}} = \frac{250}{150} = \left(\frac{5}{3}\right)$$

**Q.39** The current sensitivity of moving coil galvanometer is increased by 25%. This increase is achieved only changing in the number of turns of coils and area of cross section of the wire while keeping the resistance of galvanometer coil constant. The percentage change in the voltage sensitivity will be:

- (1) +25%                                      (2) –50%?                                      (3) –25%                                      (4) Zero

**Ans.** [1]

**Sol.**  $S_i = \frac{hBA}{k}$

$$S_v = \left(\frac{nAB}{kR}\right)$$

as R is constant

$$\Delta S_i = (\Delta S_v)$$

$$(\Delta S_v) = + 25\%$$

**Q.40** A coin placed on a rotating table just slips when it is placed at a distance of 1 cm from the centre. If the angular velocity of the table is halved, it will just slip when placed at a distance of \_\_\_\_\_ from the centre:

- (1) 8 cm                                      (2) 4 cm                                      (3) 1 cm                                      (4) 2 cm

**Ans.** [2]

**Sol.**  $f_r = (m\omega^2 r)$   
 $f_r = m(\omega')^2 (r')$   
 $\Rightarrow \omega^2 \times 1 \text{ cm} = \frac{\omega'^2}{4} r'$   
 $r' = 4 \text{ cm}$

- Q.41** A transmitting antenna is kept on the surface of the earth. The minimum height of receiving antenna required to receive the signal in line of sight at 4 km distance from it is  $x \times 10^{-2}$  m. The value of x is \_\_\_\_\_. (Let, radius of earth  $R = 6400 \text{ km}$ )  
 (1) 125 (2) 1250 (3) 12.5 (4) 1.25

**Ans.** [1]

**Sol.**  $\gamma = \sqrt{2Rh}$   
 $4 \times 10^3 = \sqrt{2 \times 6400000 \times h}$   
 $16 \times 10^6 = 2 \times 64 \times 10^5 \times h$   
 $h = \left(\frac{160}{2 \times 64}\right) \text{ m} \left(\frac{10}{8}\right) \text{ m} = \frac{1000}{8} \times 10^{-2} \text{ m} = 125 \times 10^{-2} \text{ m}$

- Q.42** 1 kg of water at  $100^\circ\text{C}$  is converted into steam at  $100^\circ\text{C}$  by boiling at atmospheric pressure. The volume of water changes from  $1.00 \times 10^{-3} \text{ m}^3$  as a liquid to  $1.671 \text{ m}^3$  as steam. The change in internal energy of the system during the process will be (Given latent heat of vaporisation =  $2257 \text{ kJ/kg}$ , Atmospheric pressure =  $1 \times 10^5 \text{ Pa}$ )  
 (1)  $-2426 \text{ kJ}$  (2)  $+2090 \text{ kJ}$  (3)  $-2090 \text{ kJ}$  (4)  $+2476 \text{ kJ}$

**Ans.** [2]

**Sol.** Work done =  $1 \times 10^5 \times (1.671 - 0.001) \text{ m}^3 = 1.670 \times 10^5 \text{ J}$   
 $\Delta Q_{\text{supplied}} = 2257 \times 1 \times 10^3 \text{ J} = 22.57 \times 10^5 \text{ J}$   
 $\Delta U = \Delta Q - \Delta W = (22.57 - 1.67) \times 10^5 \text{ J} = 20.9 \times 10^5 \text{ J} = 2090 \text{ kJ}$

- Q.43** On a temperature scale 'X', the boiling point of water is  $65^\circ\text{X}$  and the freezing point is  $-15^\circ\text{X}$ . Assuming that the X scale is linear. The equivalent temperature corresponding to  $-95^\circ\text{X}$  on the Fahrenheit scale would be :  
 (1)  $-112^\circ\text{F}$  (2)  $-48^\circ\text{F}$  (3)  $-148^\circ\text{F}$  (4)  $-63^\circ\text{F}$

**Ans.** [3]

**Sol.**  $\frac{65X - X'}{65X + 15X} = \frac{212 - F}{180}$   
 $\Rightarrow \frac{65 + 95}{80} = \frac{212 - F}{180}$   
 $2 \times 180 = 212 - F$   
 $F = 212 - 360 = -148^\circ\text{F}$

- Q.44** The logic performed by the circuit shown in figure is equivalent to

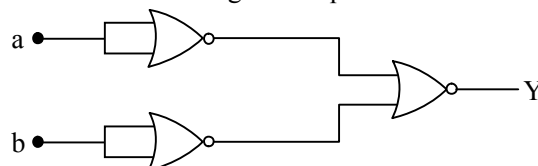

- (1) AND (2) NOR (3) OR (4) NAND

**Ans.** [1]

**Sol.**  $\overline{(\overline{A + B})} = \overline{(\overline{AB})} = (AB)$  AND gate

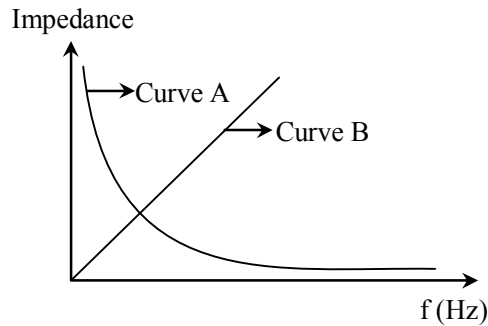
**Q.45**

As per the given graph, choose the correct representation for curve A and curve B

{Where  $X_C$  = Reactance of pure capacitive circuit connected with A.C. source

$X_L$  = Reactance of pure inductive circuit connected with A.C. source

$R$  = Impedance of pure resistive circuit connected with A.C. source

$Z$  = Impedance of the LCR series circuit}

(1)  $A = X_C, B = R$

(2)  $A = X_L, B = R$

(3)  $A = X_L, B = Z$

(4)  $A = X_C, B = X_L$

**Ans.** [4]

**Sol.**  $X_L = \omega L \rightarrow$  Curve - B

$$X_C = \left( \frac{1}{\omega C} \right) \Rightarrow \text{curve - A}$$

**Q.46** An average force of 125 N is applied on a machine gun firing bullets each of mass 10 g at the speed of 250 m/s to keep it in position. The number of bullets fired per second by the machine gun is :

(1) 50

(2) 25

(3) 100

(4) 5

**Ans.** [1]

**Sol.**  $F = n(mv)$

$$\Rightarrow 125 = n \times \frac{10}{1000} \times (250)$$

$$n = 50$$

**Q.47** The variation of kinetic energy (KE) of a particle executing simple harmonic motion with the displacement (x) starting from mean position to extreme position (A) is given by :

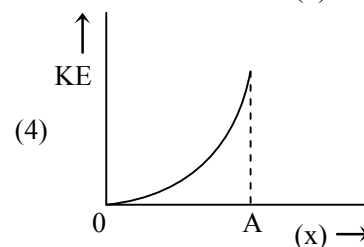
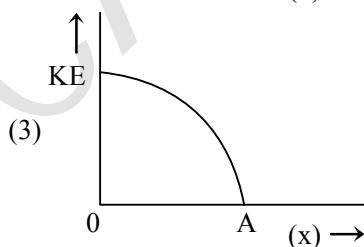
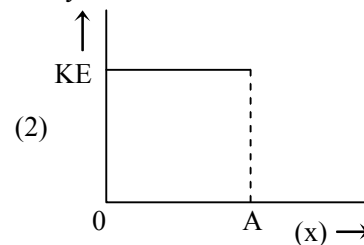
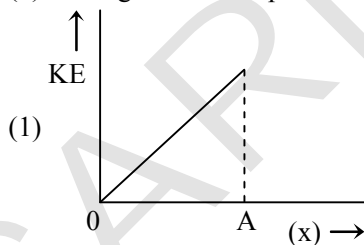

**Ans.** [3]

**Sol.**  $K.E. = \frac{1}{2} m\omega(A^2 - x^2)$

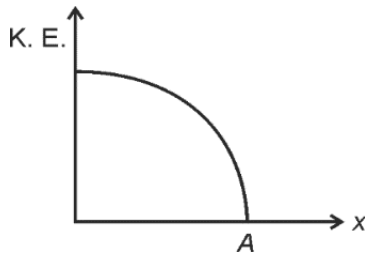

**Q.48** The critical angle for a denser-rarer interface is  $45^\circ$ . The speed of light in rarer medium is  $3 \times 10^8$  m/s. The speed of light in the denser medium is:

- (1)  $3.12 \times 10^7$  m/s      (2)  $5 \times 10^7$  m/s      (3)  $2.12 \times 10^8$  m/s      (4)  $\sqrt{2} \times 10^8$  m/s

**Ans.** [3]

**Sol.**  $\sin\theta_c = \left(\frac{1}{\mu}\right)$

$$\Rightarrow \frac{1}{\sqrt{2}} = \frac{1}{\mu} \Rightarrow \mu = \sqrt{2}$$

$$v = \frac{c}{\sqrt{2}} = \frac{3 \times 10^8}{\sqrt{2}} = 2.12 \times 10^8 \text{ m/s}$$

**Q.49** A parallel plate capacitor of capacitance 2 F is charged to a potential V. The energy stored in the capacitor is  $E_1$ . The capacitor is now connected to another uncharged identical capacitor in parallel combination. The energy stored in the combination is  $E_2$ . The ratio  $E_2/E_1$  is :

- (1) 2 : 1      (2) 2 : 3      (3) 1 : 2      (4) 1 : 4

**Ans.** [3]

**Sol.**  $Q = 2V$

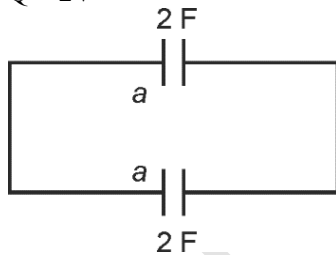

$$2V = 2V' + 2V'$$

$$V' = \left(\frac{1}{2}V\right)$$

$$E_1 = \frac{1}{2} \times 2 \times V^2 = V^2$$

$$E_2 = \frac{1}{2} \times 2 \times \frac{V^2}{4} \times 2 = \left(\frac{V^2}{2}\right)$$

$$\frac{E_2}{E_1} = \frac{V^2}{2V^2} = \left(\frac{1}{2}\right)$$

**Q.50** Given below are two statement :

**Statements I :** Astronomical unit (Au), Parsec (Pc) and Light year (ly) are units for measuring astronomical distances.

**Statements II :**  $Au < \text{Parsec (Pc)} < ly$

In the light of the above statements, choose the most appropriate answer from the options given below:

- (1) Both Statements I and Statements II are incorrect
- (2) Statements I is correct but Statements II is incorrect
- (3) Both Statements I and Statements II are correct
- (4) Statements I is incorrect but Statements II is correct

**Ans.** [2]

**Sol.** 1 Parsec =  $2 \times 10^5$  Au

1 Au =  $1.58 \times 10^{-5}$  ly

1 Au < ly < Parsec

**Section-B: Numerical Value Type Questions:** This section contains 10 questions. In Section B, attempt any five questions out of 10. The answer to each question is a **NUMERICAL VALUE**. For each question, enter the correct numerical value (in decimal notation, truncated/rounded-off to the second decimal place; e.g. 06.25, 07.00, -00.33, -00.30, 30.27, -27.30) using the mouse and the on-screen virtual numeric keypad in the place designated to enter the answer.

**Q.51** A force  $\vec{F} = (2 + 3x) \hat{i}$  acts on a particle in the x direction where F is in newton and x is in meter. The work done by this force during a displacement from  $x = 0$  to  $x = 4$  m, is \_\_\_\_\_ J.

**Ans.** [32]

**Sol.**  $W = \int F dx = \int_0^4 (2 + 3x) dx = \left[ 2x + \frac{3}{2}x^2 \right]_0^4 = [8 + 24] = 32J$

**Q.52** The magnetic field B crossing normally a square metallic plate of area  $4 \text{ m}^2$  is changing with time as shown in figure. The magnitude of induced emf in the plate during  $t = 2$  s to  $t = 4$  s, is \_\_\_\_\_ mV.

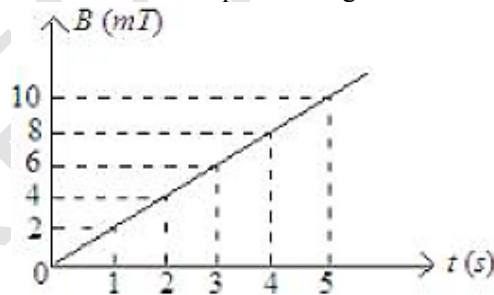

**Ans.** [8]

**Sol.**  $\phi = BA$

$$\frac{d\phi}{dt} = \epsilon_{\text{ind}}$$

$$\epsilon_{\text{ind}} = A \frac{dB}{dt} = 4 \times \left( \frac{4}{2} \right) = 8 \text{ mV}$$

**Q.53** The length of a wire becomes  $l_1$  and  $l_2$  when 100 N and 120 N tension are applied respectively. If  $10l_2 = 11l_1$ , then the natural length of wire will be  $\frac{1}{x} l_1$ . Here the value of x is

**Ans.** [2]

Sol.  $\frac{F}{A} = Y \left( \frac{\Delta \ell}{\ell} \right)$

$$\Delta \ell = \left( \frac{FL}{AY} \right)$$
$$\ell + \Delta \ell = \ell_1 = \left( \frac{FL}{AY} + L \right) = L \left( \frac{F_1}{AY} + 1 \right)$$
$$\ell_2 = \left( \frac{F_2}{AY} + 1 \right) L$$
$$\Rightarrow 10 \ell_2 = 11 \ell_1$$
$$\Rightarrow 10 \times L \left[ \frac{F_2}{AY} + 1 \right] = 11L \left[ \frac{F_1}{AY} + 1 \right]$$
$$\Rightarrow \frac{10F_2}{AY} + 10 = \frac{11F_1}{AY} + 11$$
$$\Rightarrow \frac{1200}{AY} - \frac{1100}{AY} = 1 \Rightarrow \frac{100}{AY} = 1$$
$$\Rightarrow \frac{1}{AY} = \frac{1}{100}$$

So,  $L = \frac{\ell_1}{\left( \frac{F_1}{AY} + 1 \right)} = \frac{\ell_1}{\frac{100}{100} + 1} = \frac{\ell_1}{2}$

**Q.54** A monochromatic light is incident on a hydrogen sample in ground state. Hydrogen atoms absorb a fraction of light and subsequently emit radiation of six different wavelengths. The frequency of incident light is  $x \times 10^{15}$  Hz. The value of x is \_\_\_\_\_.  
(Given  $h = 4.25 \times 10^{-15}$  eVs)

**Ans.** [3]

**Sol.**  $\frac{n(n-1)}{2} = 6$

$$\Rightarrow n = 6$$

For hydrogen atom,

$$\Delta \varepsilon = 13.6 \left( \frac{1}{1} - \frac{1}{16} \right) = 13.6 \times \frac{15}{16} \text{ eV}$$

$$hf = E$$

$$\Rightarrow f = \frac{E}{h} = \frac{13.6 \times 15}{16 \times 4.25 \times 10^{-15}} = 3 \times 10^{15} \text{ Hz}$$

**Q.55** A solid sphere of mass 500 g radius 5 cm is rotated about one of its diameter with angular speed of  $10 \text{ rad s}^{-1}$ . If the moment of inertia of the sphere about its tangent is  $x \times 10^{-2}$  times its angular momentum about the diameter. Then the value of x will be \_\_\_\_\_

**Ans.** [35]

**Sol.**  $L_{\text{diameter}} = \frac{2}{5} MR^2 \omega$  ;  $I_{\text{tangent}} = \frac{7}{5} MR^2$

$$\frac{I_{\text{tangent}}}{L_{\text{diameter}}} = \frac{7/5}{2/5} \times \frac{1}{\omega} = \frac{7}{2\omega} = \frac{7}{2 \times 10} = \frac{7}{20} = \frac{700}{20} \times 10^{-2} = 35 \times 10^{-2}$$

**Q.56** A projectile fired at  $30^\circ$  to the ground is observed to be at same height at time 3 s and 5 s after projection, during its flight. The speed of projection of the projectile is \_\_\_\_\_  $\text{ms}^{-1}$ . (Given  $g = 10 \text{ ms}^{-2}$ )

**Ans.** [80]

**Sol.** 
$$\left(\frac{T}{2}\right) = \left(\frac{3+5}{2}\right) = \left(\frac{u \sin \theta}{g}\right)$$

$$\Rightarrow 4 = \frac{(u) \times \frac{1}{2}}{10} = u = 80 \text{ m/s}$$

**Q.57** As shown in the figure, a configuration of two equal point charges ( $q_0 = +2\mu \text{ C}$ ) is placed on an inclined plane. Mass of each point charge is 20 g. Assume that there is no friction between charge and plane. For the system of two point charges to be in equilibrium (at rest) the height  $h = x \times 10^{-3} \text{ m}$ . The value of  $x$  is \_\_\_\_\_.

(Take  $\frac{1}{4\pi\epsilon_0} = 9 \times 10^9 \text{ N m}^2\text{C}^{-2}$ ,  $g = 10 \text{ ms}^{-2}$ )

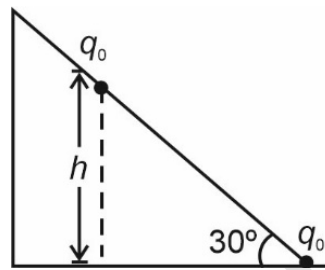

**Ans.** [300]

**Sol.**

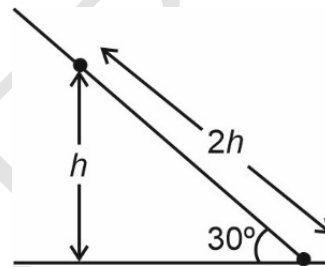

$$\frac{kq^2}{4h^2} = (mg \sin \theta) = 20 \times 10 \times \frac{1}{2} \times 10^{-3}$$

$$\Rightarrow \frac{9 \times 10^9 \times 4 \times 10^{-12}}{4h^2} = 10^{-1}$$

$$\Rightarrow \frac{9}{h^2} = 10^2$$

$$h^2 = \left(\frac{9}{100}\right) \Rightarrow h = \left(\frac{3}{10}\right) \text{ m} = 0.3 \text{ m}$$

$$= 300 \times 10^{-3} \text{ m}$$

**Q.58** The equation of wave is given by  $Y = 10^{-2} \sin 2\pi (160t - 0.5x + \pi/4)$  Where  $x$  and  $Y$  are in m and  $t$  in s. The speed of the wave is \_\_\_\_\_  $\text{km h}^{-1}$ .

**Ans.** [1152]

**Sol.** Speed of wave =  $\left(\frac{160}{0.5}\right) = 320 \text{ m/s} = 320 \times \frac{18}{5} = 1152 \text{ km/hr}$

- Q.59** In the circuit diagram shown in figure given below, the current flowing through resistance  $3\ \Omega$  is  $\frac{x}{3}$  A. The value of x is \_\_\_\_\_.

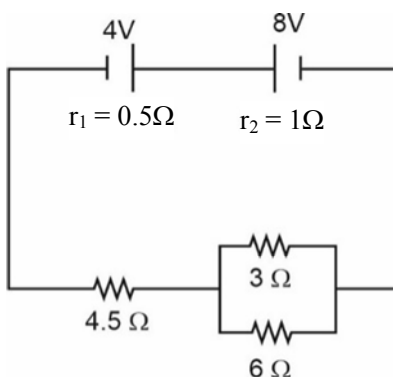

**Ans.** [1]

**Sol.**  $I = \frac{8-4}{8} = 0.5\text{ A}$

$$I_3 = \frac{6}{9} \times 0.5 = \frac{2}{3} \times \frac{1}{2} = \frac{1}{3}\text{ A}$$

- Q.60** The radius of curvature of each surface of a convex lens having refractive index 1.8 is 20 cm. The lens is now immersed in a liquid of refractive index 1.5. The ratio of power of lens in air to its power in the liquid will be  $x : 1$ . The value of x is \_\_\_\_\_

**Ans.** [4]

**Sol.**  $P_1 = \frac{1}{f} = (1.8 - 1) \left( \frac{1}{R_1} - \frac{1}{R_2} \right)$

$$P_2 = \frac{1}{f_{\text{immersed}}} = \left( \frac{1.8}{1.5} - 1 \right) \left( \frac{1}{R_1} - \frac{1}{R_2} \right)$$

$$\frac{P_1}{P_2} = \frac{(1.8-1)}{\left(\frac{1.8}{1.5}-1\right)} = \frac{0.8 \times 1.5}{0.3} = 4$$

## CHEMISTRY

**Section-A: Multiple Choice Questions:** This section contains 20 multiple choice questions. Each question has 4 choices (1), (2), (3) and (4), out of which **ONLY ONE** is correct.

**Choose the correct answer:**

- Q.61** Match List-I with List-II:

List-I Species		List-II Geometry/Shape	
A.	$\text{H}_3\text{O}^+$	I.	Tetrahedral
B.	Acetylide anion	II.	Linear
C.	$\text{NH}_4^+$	III.	Pyramidal
D.	$\text{ClO}_2^-$	IV.	Bent

Choose the correct answer from the options given below:

- (1) A(III), B(IV), C(I), D(II)  
 (3) A(III), B(II), C(I), D(IV)

- (2) A(III), B(I), C(II), D(IV)  
 (4) A(III), B(IV), C(II), D(I)



**Ans.** [3]

- Sol.** (A)  $\text{H}_3\text{O}^+$  → (III) Pyramidal  
 (B) Acetylide ion → (II) Linear  
 (C)  $\text{NH}_4^+$  ion → (I) Tetrahedral  
 (D)  $\text{ClO}_2^-$  ion → (IV) Bent

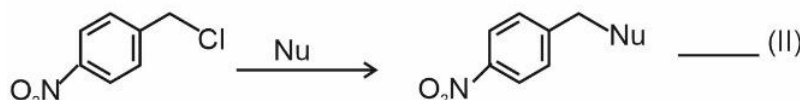
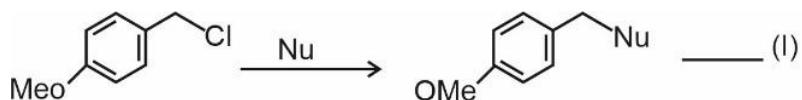
**Q.62**

Where Nu = Nucleophile

Find out the correct statement from the options given below for the above 2 reactions.

- (1) Reaction (I) is of 2<sup>nd</sup> order and reaction (II) is of 1<sup>st</sup> order
- (2) Reactions (I) and (II) both are of 2<sup>nd</sup> order
- (3) Reaction (I) is of 1<sup>st</sup> order and reaction (II) is of 2<sup>nd</sup> order
- (4) Reaction (I) and (II) both are of 1<sup>st</sup> order

**Ans.** [3]

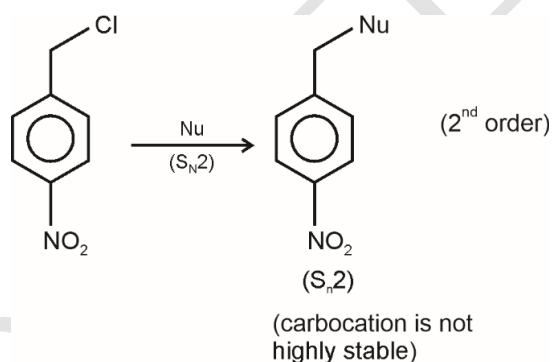
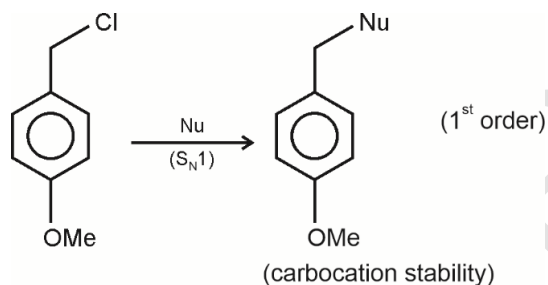
**Sol.**

**Q.63**

 For compound having the formula  $\text{GaAlCl}_4$ , the correct option from the following is :

- (1) Ga is coordinated with Cl in  $\text{GaAlCl}_4$
- (2) Ga is more electronegative than Al and is present as a cationic part of the salt  $\text{GaAlCl}_4$
- (3) Cl forms bond with both Al and Ga in  $\text{GaAlCl}_4$
- (4) Oxidation state of Ga in the salt  $\text{GaAlCl}_4$  is +3.

**Ans.** [2]

**Sol.**  $\text{GaAlCl}_4$  exists as  $\text{Ga}^+ \text{AlCl}_4^-$ .

However, Ga is more electronegative than Al.

**Q.64** L-isomer of tetrose X(C<sub>4</sub>H<sub>8</sub>O<sub>4</sub>) gives positive Schiff's test and has two chiral carbons. On acetylation 'X' yields triacetate. 'X' also undergoes following reactions.

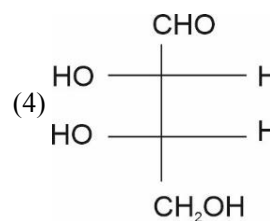
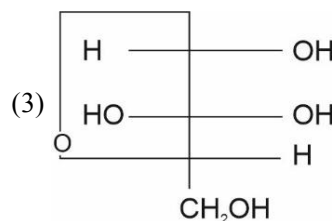
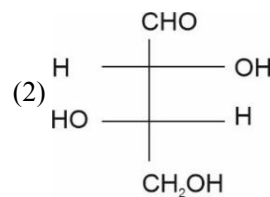
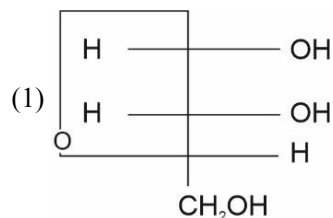
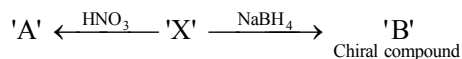

**Ans.** [2]  
**Sol.**

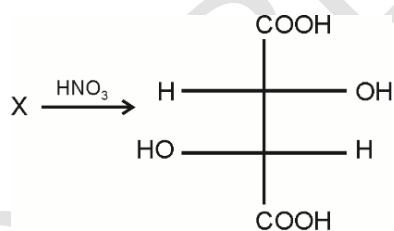
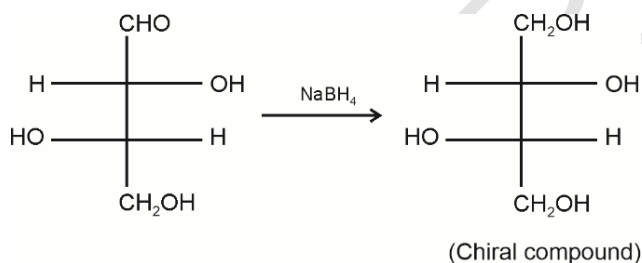
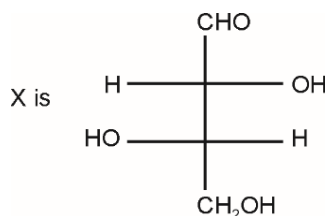

**Q.65** Match List-I with List-II:

List-I		List-II	
A.	K	I.	Thermonuclear reactions
B.	KCl	II.	Fertilizer
C.	KOH	III.	Sodium potassium pump
D.	Li	IV.	Absorbent of CO <sub>2</sub>

(1) A(III), B(II), C(IV), D(I)  
(3) A(IV), B(I), C(III), D(II)

(2) A(III), B(IV), C(II), D(I)  
(4) A(IV), B(III), C(I), D(II)

**Ans.** [1]

**Sol.** Lithium (Li) → Thermonuclear reactions

$K^+$  ions → Sodium potassium pump

KOH → absorbent of  $CO_2$

KCl → fertilizer

**Q.66** o-Phenylenediamine  $\xrightarrow{HNO_3}$  'X' Major Product  
'X'

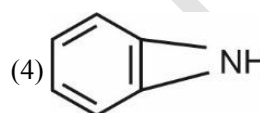
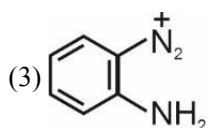
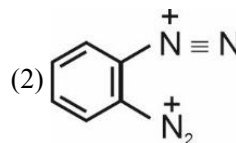
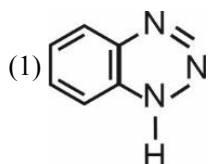

**Ans.** [1]

**Sol.**

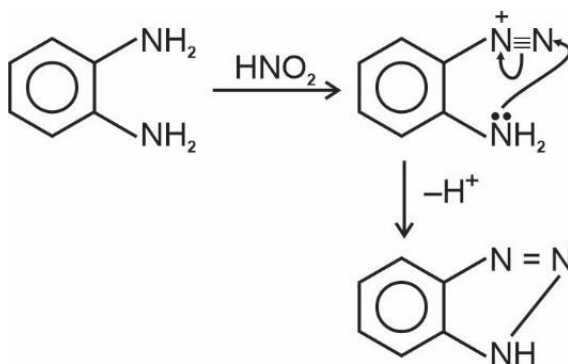

**Q.67** 25 mL of silver nitrate solution (1M) is added dropwise to 25 mL of potassium iodide (1.05 M) solution. The ion(s) present in very small quantity in the solution is/are :

(1)  $I^-$  only

(2)  $K^+$  only

(3)  $NO_3^-$  only

(4)  $Ag^+$  and  $I^-$  both

**Ans.** [4]

**Sol.** millimoles of  $AgNO_3 = 25$

millimoles of  $KI = 25 \times 1.05$

∴, KI is in excess & AgI forms negatively charged colloid. (Some  $Ag^+$  remains in solution) Ions  $Ag^+$  &  $I^-$  are therefore, present in very small quantity.

**Q.68** Arrange the following compounds in increasing order of rate of aromatic electrophilic substitution reaction.

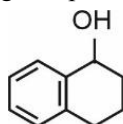

a

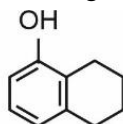

b

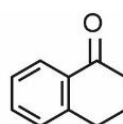

c

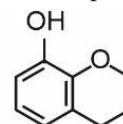

d

(1) d, b, c, a

(2) d, b, a, c

(3) b, c, a, d

(4) c, a, b, d

**Ans.** [4]

**Sol.**

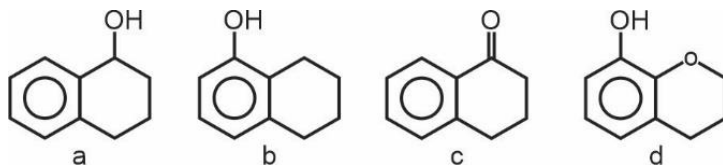

Correct increasing order is :

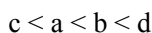

**Q.69** The complex that dissolves in water is

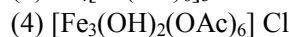
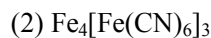

**Ans.** [4]

**Sol.**  $[\text{Fe}_3(\text{OH})_2(\text{OAc})_6]\text{Cl}$  dissolves in water. Rest of the complexes form ppt.

**Q.70** The polymer X-consists of linear molecules and is closely packed. It is prepared in the presence of triethylaluminium and titanium tetrachloride under low pressure. The polymer X is

(1) High density polythene

(2) Polyacrylonitrile

(3) Low density polythene

(4) Polytetrafluoroethane

**Ans.** [1]

**Sol.** In presence of Ziegler Natta catalyst, high density polythene is prepared.

**Q.71** The set which does not have ambidentate ligand(s) is :

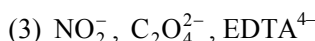
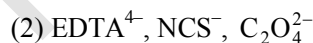
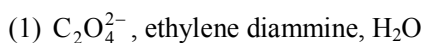

**Ans.** [1]

**Sol.**  $\text{C}_2\text{O}_4^{2-}$ , ethylenediamine and  $\text{H}_2\text{O}$  are not ambidentate.

**Q.72** When a solution of mixture having two inorganic salts was treated with freshly prepared ferrous sulphate in acidic medium, a dark brown ring was formed whereas on treatment with neutral  $\text{FeCl}_3$ , it gave deep red colour which disappeared on boiling and a brown red ppt was formed. The mixture contains

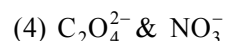
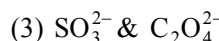

**Ans.** [2]

**Sol.** Dark brown ring is formed in the confirmatory test of  $\text{NO}_3^-$  ions.

Deep red ppt. with  $\text{FeCl}_3$  is formed in the presence of  $\text{CH}_3\text{COO}^-$  ions.

**Q.73** Given below are two statements :

**Statement-I :** Methane and steam passed over a heated Ni catalyst produces hydrogen gas.

**Statement-II :** Sodium nitrite reacts with  $\text{NH}_4\text{Cl}$  to give  $\text{H}_2\text{O}$ ,  $\text{N}_2$  and  $\text{NaCl}$ .

In the light of the above statements, choose the most appropriate answer from the options given below :

(1) Statement I is incorrect but Statement II is correct

(2) Both the statements I and II are incorrect

(3) Statement I is correct but Statement II is incorrect

(4) Both the statements I and II are correct

**Ans.** [4]

**Sol.** Statement I is correct as  $\text{CH}_4$  and steam in presence of Ni catalyst forms water gas ( $\text{CO} + \text{H}_2$ ).

Statement II is also correct.

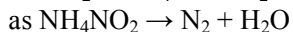
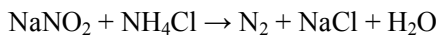

Q.74 Given below are two statements :

**Statement-I :** If BOD is 4 ppm and dissolved oxygen is 8 ppm, then it is a good quality water.

**Statement-II :** If the concentration of zinc and nitrate salts are 5 ppm each, then it can be a good quality water.

In the light of the above statements, choose the most appropriate answer from the options given below :

- (1) Statement I is correct but Statement II is incorrect
- (2) Statement I is incorrect but Statement II is correct
- (3) Both the statements I and II are incorrect
- (4) Both the statements I and II are correct

Ans. [4]

Sol.  $BOD < 5$  ppm for clean water.

Dissolved oxygen  $> 6$  ppm is acceptable for water.

Threshold concentration for  $NO_3^- \rightarrow 50$  ppm

Zn  $\rightarrow 5$  ppm.

Hence, water is of good quality.

Q.75 In the extraction process of copper, the product obtained after carrying out the reactions

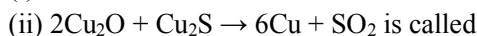
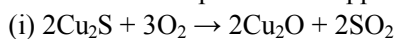

- (1) Blister copper                      (2) Reduced copper                      (3) Copper scrap                      (4) Copper matte

Ans. [1]

Sol. The reactions given are carried out in the production of blister copper using self reduction.

Q.76 Given below are two statements : one is labelled as Assertion A and the other is labelled as Reason R :

**Assertion A:** In the photoelectric effect, the electrons are ejected from the metal surface as soon as the beam of light of frequency greater than threshold frequency strikes the surface.

**Reason R :** When the photon of any energy strikes an electron in the atom, transfer of energy from the photon to the electron takes place.

In the light of the above statements, choose the most appropriate answer from the options given below :

- (1) Both A and R are correct and R is the correct explanation of A
- (2) A is correct but R is not correct
- (3) Both A and R are correct but R is NOT the correct explanation of A
- (4) A is not correct but R is correct

Ans. [2]

Sol. A is correct as electrons are ejected when Incident frequency  $>$  Threshold frequency R is incorrect as atoms are ionised resulting in transfer of energy when photons of sufficient energy strike the metal surface.

Q.77 For elements B, C, N, Li, Be, O and F, the correct order of first ionization enthalpy is :

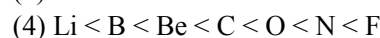
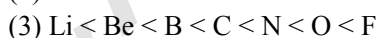
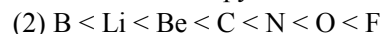
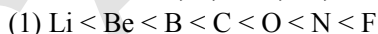

Ans. [4]

Sol. Correct order of 1st ionisation energy.  $Li < B < Be < C < O < N < F$

Q.78 Which of the following complex has a possibility to exist as meridional isomer?

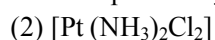
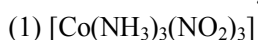

Ans. [1]

Sol.  $[Co(NH_3)_3(NO_2)_3]$  can show facial and meridional isomerism.

Q.79 Thin layer chromatography of a mixture shows the following observation:

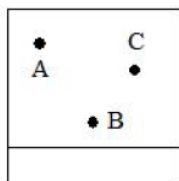

The correct order of elution in the silica gel column chromatography is :

- (1) B, A, C                      (2) B, C, A                      (3) A, C, B                      (4) C, A, B

Ans. [3]

Sol. Correct order of elution  $\rightarrow A > C > B$

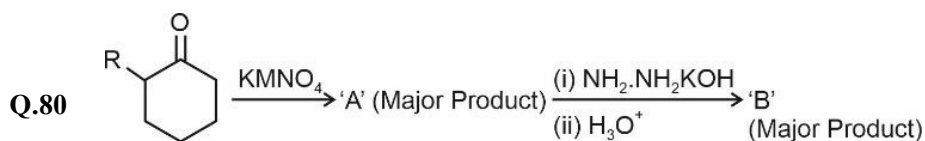

(R = alkyl)  
‘A’ and ‘B’ in the above reactions are:

- (1) = A, B =
- (2) = A, B =
- (3) = A, B =
- (4) = A, B =

Ans. [2]

Sol.

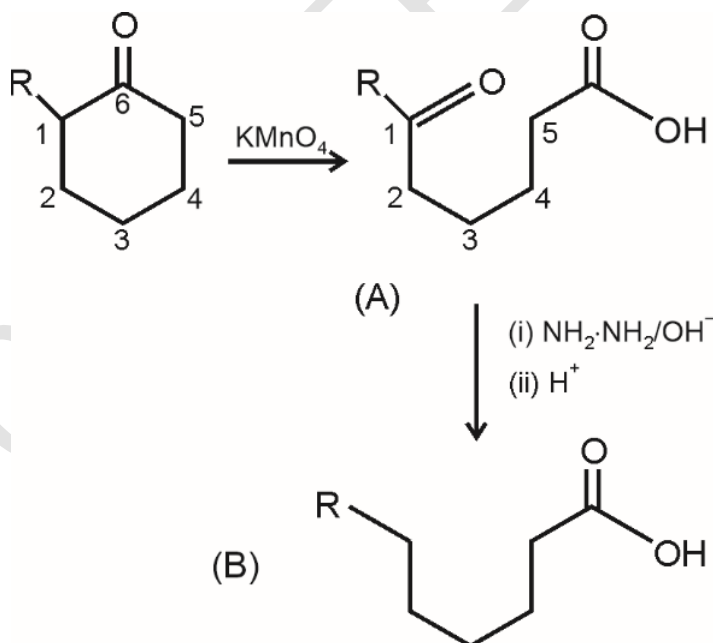

**Section-B: Numerical Value Type Questions:** This section contains 10 questions. In Section B, attempt any five questions out of 10. The answer to each question is a **NUMERICAL VALUE**. For each question, enter the correct numerical value (in decimal notation, truncated/rounded-off to the second decimal place; e.g., 06.25, 07.00, -00.33, -00.30, 30.27, -27.30) using the mouse and the on-screen virtual numeric keypad in the place designated to enter the answer.

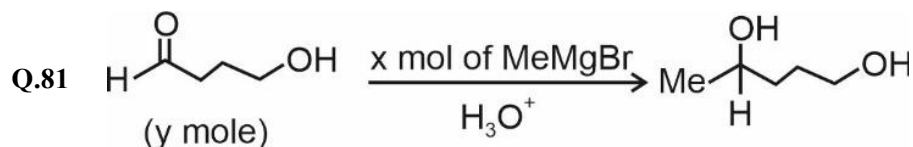

The ratio x/y on completion of the above reaction is \_\_\_\_\_.

Ans. [2]

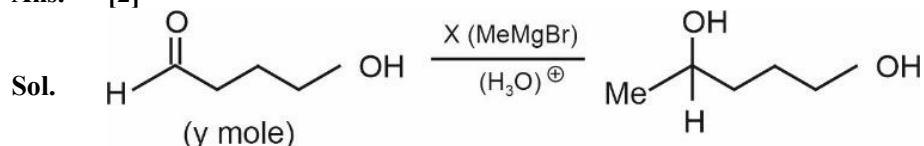

For completion of reaction, we need 2 moles of MeMgBr per mole of reactant 1 mole for nucleophilic addition and 1 mole for acid base reaction.

Q.82 Solid fuel used in rocket is a mixture of  $\text{Fe}_2\text{O}_3$  and Al (in ratio 1 : 2). The heat evolved (kJ) per gram of the mixture is \_\_\_\_\_ (Nearest integer)

Given :  $\Delta H_f^\circ (\text{Al}_2\text{O}_3) = -1700 \text{ kJ mol}^{-1}$

$\Delta H_f^\circ (\text{Fe}_2\text{O}_3) = -840 \text{ kJ mol}^{-1}$

Molar mass of Fe, Al and O are 56, 27 and 16  $\text{g mol}^{-1}$  respectively

Ans. [4]

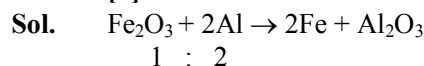

$\Delta H_{\text{reaction}}^\circ = -1700 + (840) = -860 \text{ kJ}$

Mass ratio of  $\text{Fe}_2\text{O}_3$  and Al

= 160 : 54 = 2.96 in 214 gm mixture

$\therefore \frac{\Delta H^\circ}{1 \text{ gm mixture}} = \frac{-860}{214} = -4 \text{ kJ/gram}$

Q.83 The ratio of spin-only magnetic moment values  $\mu_{\text{eff}}$   $[\text{Cr}(\text{CN})_6]^{3-}/\mu_{\text{eff}}[\text{Cr}(\text{H}_2\text{O})_6]^{3+}$  is \_\_\_\_\_.

Ans. [1]

Sol.  $\mu_{\text{eff}}$  of  $[\text{Cr}(\text{CN})_6]^{3-} = \sqrt{15} \text{ BM}$

$\mu_{\text{eff}}$  of  $[\text{Cr}(\text{H}_2\text{O})_6]^{3+} = \sqrt{15} \text{ BM}$

Ratio = 1

Q.84 0.004 M  $\text{K}_2\text{SO}_4$  solution is isotonic with 0.01 M glucose solution. Percentage dissociation of  $\text{K}_2\text{SO}_4$  is \_\_\_\_\_ (Nearest integer)

Ans. [75]

Sol. As osmotic pressure are equal, we have

$(0.004) \times i = 0.01$

$\Rightarrow i = \frac{0.01}{0.004} = \frac{10}{4} = \frac{5}{2} = 1 + 2\alpha$

$2\alpha = 1.5$

$\alpha = 0.75$

$\% \alpha = 75$



The above reaction was studied at 300 K by monitoring the concentration of  $\text{FeSO}_4$  in which initial concentration was 10 M and after half an hour became 8.8 M. The rate of production of  $\text{Fe}_2(\text{SO}_4)_3$  is \_\_\_\_\_  $\times 10^{-6} \text{ mol L}^{-1} \text{ s}^{-1}$ .

(Nearest integer)

**Ans.** [333]

**Sol.** Rate of decomposition of  $\text{FeSO}_4 = \frac{(10 - 8.8)}{30 \times 3600} = \frac{1.2 \times 60}{3600 \times 30} \text{ mol L}^{-1} \text{ s}^{-1}$

Rate of production of  $\text{Fe}_2(\text{SO}_4)_3$

$$\begin{aligned} &= \frac{0.6 \times 60}{3600 \times 30} = 3.33 \times 10^{-4} \\ &= 333.3 \times 10^{-6} \text{ mol}^{-1} \text{ s}^{-1} \end{aligned}$$

**Q.86** An atomic substance A of molar mass  $12 \text{ g mol}^{-1}$  has a cubic crystal structure with edge length of 300 pm. The no. of atoms present in one unit cell of A is

(Nearest integer)

Given the density of A is  $3.0 \text{ g mL}^{-1}$  and  $N_A = 6.02 \times 10^{23} \text{ mol}^{-1}$

**Ans.** [4]

**Sol.**  $\rho = \frac{z \times M}{N_A \times a^3}$

$$3 = \frac{z \times 12}{6.02 \times 10^{23} \times (3 \times 10^{-8})^3 \times 10^{-24}}$$

$$z = \frac{6.02 \times 10^{-1} \times 27}{4} \approx 4$$

**Q.87** In an electrochemical reaction of lead, at standard temperature, if  $E^\circ_{(\text{Pb}^{2+}/\text{Pb})} = m \text{ Volt}$  and  $E^\circ_{(\text{Pb}^{4+}/\text{Pb})} = n \text{ Volt}$ , then the value of  $E^\circ_{(\text{Pb}^{2+}/\text{Pb}^{4+})}$  is given by  $m - xn$ . The value of  $x$  is \_\_\_\_\_. (Nearest integer)

**Ans.** [2]

**Sol.**  $4E^\circ_{\text{Pb}^{4+}/\text{Pb}} = 2E^\circ_{\text{Pb}^{2+}/\text{Pb}} + 2E^\circ_{\text{Pb}^{4+}/\text{Pb}^{2+}}$

$$2n = m + E^\circ_{\text{Pb}^{4+}/\text{Pb}^{2+}}$$

$$E^\circ_{\text{Pb}^{2+}/\text{Pb}^{4+}} = m - 2n$$

$$\therefore x = 2$$

**Q.88** A solution of sugar is obtained by mixing 200 g of its 25% solution and 500 g of its 40% solution (both by mass). The mass percentage of the resulting sugar solution is \_\_\_\_\_ (Nearest integer)

**Ans.** [36]

**Sol.** Mass of solution =  $200 + 500 = 700 \text{ g}$

$$\text{Mass of sugar} = 0.25 \times 200 + 0.40 \times 500$$

$$= 50 + 200 = 250 \text{ g}$$

Mass % of resulting solution

$$= \frac{250}{700} \times 100 \approx 36$$



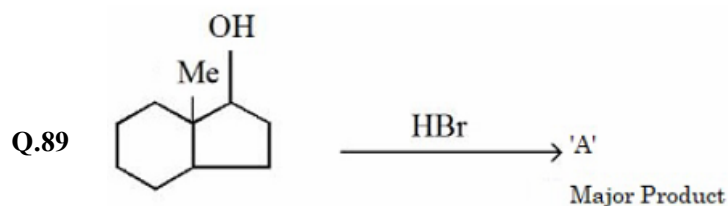

The number of hyperconjugation structures involved to stabilize carbocation formed in the above reaction is

Ans. [7]  
Sol.

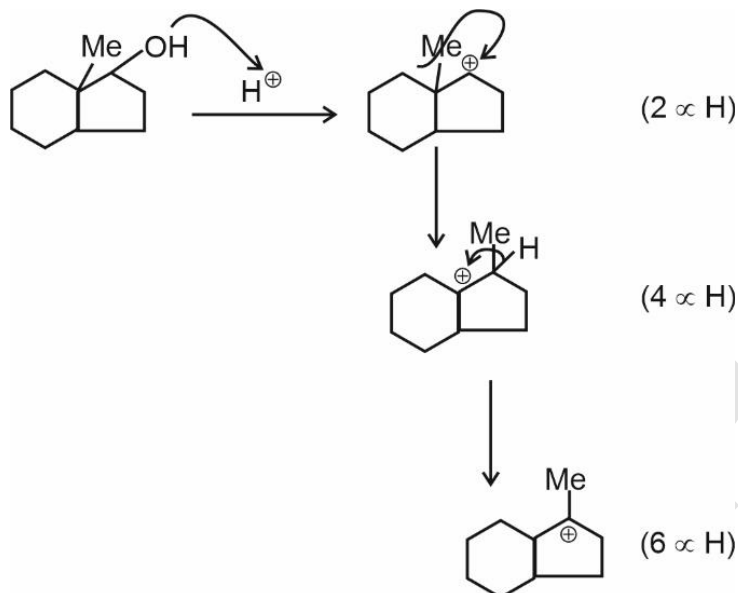

So, number of hyperconjugation structures in most stable carbocation  
= 6 + 1 = 7

Q.90 A mixture of 1 mole of  $\text{H}_2\text{O}$  and 1 mole of  $\text{CO}$  is taken in a 10 litre container and heated to 725 K. At equilibrium 40% of water by mass reacts with carbon monoxide according to the equation:  
 $\text{CO}(\text{g}) + \text{H}_2\text{O}(\text{g}) \rightleftharpoons \text{CO}_2(\text{g}) + \text{H}_2(\text{g})$ . The equilibrium constant  $K_c \times 10^2$  for the reaction is \_\_\_\_\_  
(Nearest integer)

Ans. [44]  
Sol.

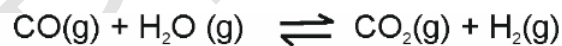

Initial	1	1		
Final	1 - 0.4	1 - 0.4	0.4	0.4
$\therefore$ Equilibrium constant = $\frac{0.16}{0.36}$				
= 0.44				
$\therefore, K_c \times 10^2 = 44$				